

BO125L BOPLAN BOLLARDS AND HEIGHT LIMITERS

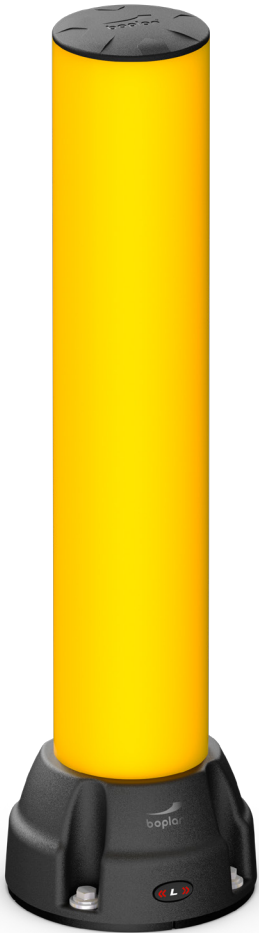

Revision: 8 March 2024 5:14 PM
Boplan reference: BO125L...



PRODUCT SPECIFICATIONS

APPLICATION		
Environment	The BO125L is the lightest in the series of impact-resistant Boplan bollards. The BO125L is often selected to protect gates, access ways, corners, building facades, loading platforms and machines from collisions involving minor impact risk. The hidden fixations prevent damage to passing goods and vehicles. Due to the large Base, pallets are kept at a certain distance from the bollard to protect hands and prevent injury. Suitable for both indoor and outdoor environments.	
Impact performance	2500 Joule (Eq. to 3.8 ton - 2.54 mph)	
MATERIAL		
Tube	Extrilene® - UV resistant - Fire class E ⁺ - Non conductive - Impervious to most chemicals**	
Cap	Sustainable elastomer	
Base Defender	Sustainable elastomer	
COLORS		
Bollard	Standard: Yellow RAL 1003 Also available in Black RAL 9005 (Multicolor)	
Base Defender	Standard: Black RAL 9005	
OPTIONAL		
Stripe	Colored reflective stripe providing a high level of visibility	
BASEPLATES		
	Zinc Coated Steel	Stainless steel
Material	Steel 37	Stainless steel 304
Coating	Electroplated + Lacquered	No lacquer / No coating
Color	Mat black	Natural color

*Classification according to EN 13501-1:2007 +A1:2009 - Fire classification of construction products and building elements.
**Ask your local sales office for resistance to specific chemicals.

FIXATIONS			ZC (Zinc coated)	SS (Stainless steel)
STANDARD	Concrete screw		Ø12mm x 100mm	Not available
	Wedge anchor		Ø12mm (M12) x 135mm	M12 x 120mm
ALTERNATIVE	Asphalt anchor		Bolt M10 x 40mm + Screw Ø16mm	Not available







Base Defender with Impact Button

FEATURES AND FUNCTIONALITY - B0125L

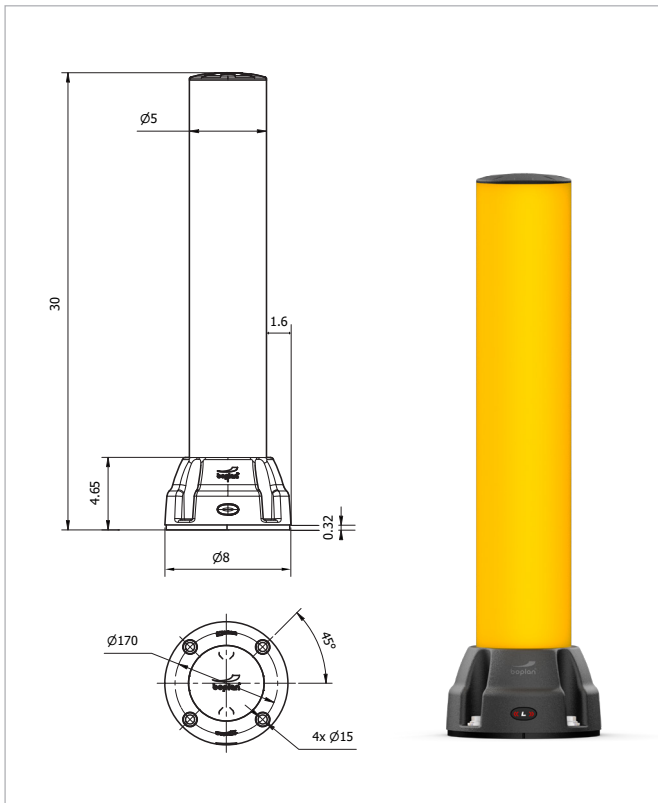
SIZE	
Height	18 in 30 in 40 in 18-40 in
Profile section	Ø5 in (0.4 in thick)
Baseplate	Ø8 in (0.3 in thick)
Base Defender	Top: Ø5 in Base: Ø8 in Height: 4.3 in

REQUIREMENTS	
Concrete quality	minimum C25/30
Concrete floor plate thickness (in)	minimum 6 in
Concrete slab dimension around posts (in)	20 (h) x 20 (w) x 12 (d)
Operational temperature	14°F up to 104°F
Water and humidity	Zinc coated: Indoor and outdoor use in most environments. Stainless steel: outdoor use or frequent exposure to water and humidity.



boplan		IMPACT LABEL FOR SAFETY BARRIERS	
BOPLAN B0125L			
IMPACT RATING			
E50	< 50 kJ		
E40	< 40 kJ		
E30	< 30 kJ		
E25	< 25 kJ		
E20	< 20 kJ		
E15	< 15 kJ		
E12	< 12 kJ		
E10	< 10 kJ		
E7	< 7.5 kJ		
E5	< 5.0 kJ		
E2	< 2.5 kJ		
E1	< 1.0 kJ		
IMPACT RESULTS	 α = 20.4° Deflection: At maximum impact energy D = 261.4 mm / 10.3 inch	SUCCESS CRITERIA VEHICLE STOPPED ASI (ACCELERATION SEVERITY INDEX) < 0.5	
TEST CONDITIONS	TEMPERATURE: 20°C / 68°F IMPACT HEIGHT: 300 mm / 11.8 inch → D: 261.4 mm / 10.3 inch → α: 20.4° TEST FLOOR: CONCRETE SLAB C25/30 - 150 mm / 6 inch	BOPLAN TEST LAB Muizelstraat 12 8560 Moorsele Belgium 	
TEST VEHICLE:	TYPE: BOPLAN IMPACT TEST VEHICLE WEIGHT: 3775 Kg / 8322.45 lbs SIZE (L x W x h): 3100 x 1100 x 1150 mm / 122 x 43 1/4 x 45 1/4 inch CONTACT AREA, STEEL BUMPER WIDTH: 1000 mm / 39 1/4 inch	IL-B0125L-20240207	

FEATURES AND FUNCTIONALITY - B0125L

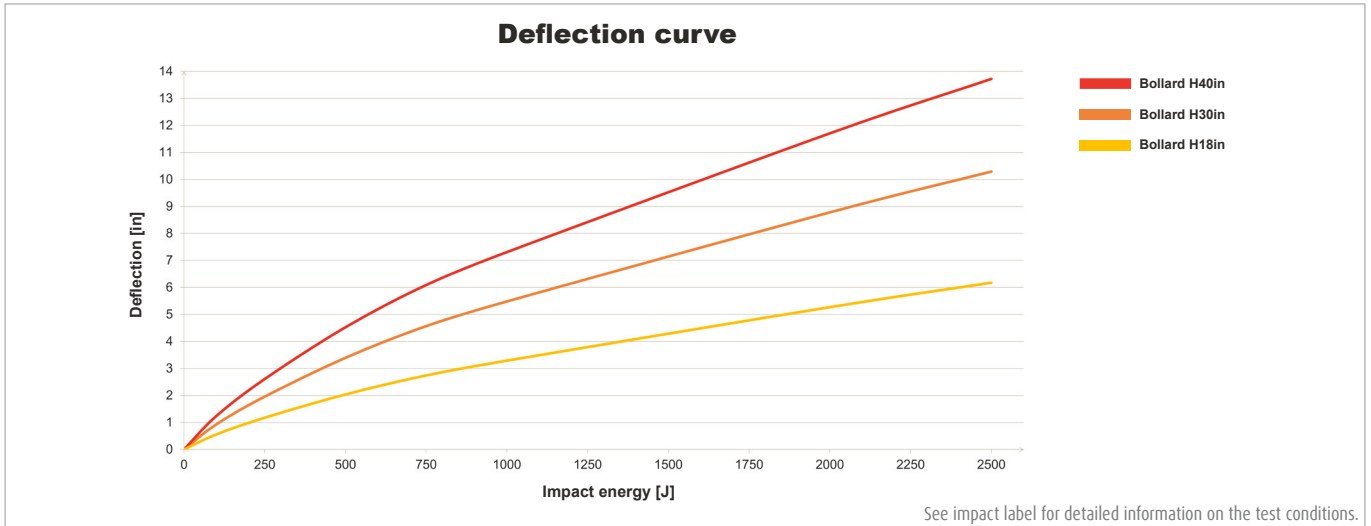

REFERENCE LIST - B0125L

	ZINC COATED (ZC)		STAINLESS STEEL (SS)	
	YELLOW	MULTICOLOR ■	YELLOW	MULTICOLOR ■
18 in	B0125L0-0450-0001YEZ	B0125L0-0450-0001MCZ	B0125L0-0450-0001YES	B0125L0-0450-0001MCS
30 in	B0125L0-0750-0001YEZ	B0125L0-0750-0001MCZ	B0125L0-0750-0001YES	B0125L0-0750-0001MCS
40 in	B0125L0-1000-0001YEZ	B0125L0-1000-0001MCZ	B0125L0-1000-0001YES	B0125L0-1000-0001MCS
18 - 40 mm	B0125L1-1000-0001YEZ	B0125L1-1000-0001MCZ	B0125L1-1000-0001YES	B0125L1-1000-0001MCS

STRIPES (not included)			
	Black	White	Yellow
1 STRIPE*	PA0300-0125-0001BL	PA0300-0125-0001WH	PA0300-0125-0001YE
			

* Remark: Stripes cannot be ordered separately