

FLIP 180M

INSTALLATION SHEET

Reference: PL180...

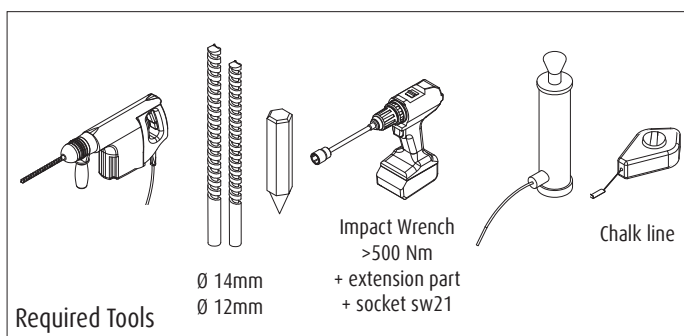
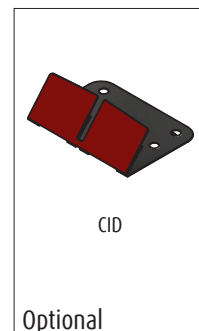
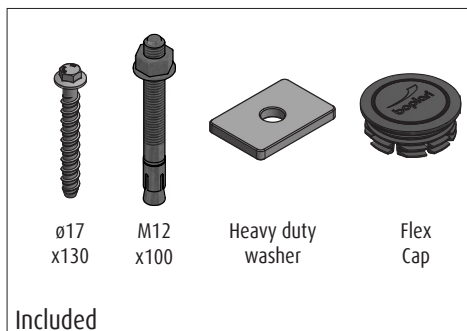

Optional CID

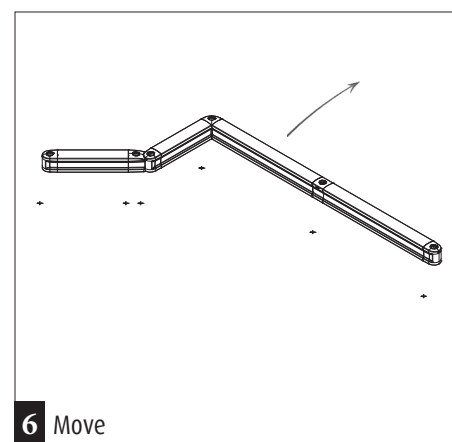
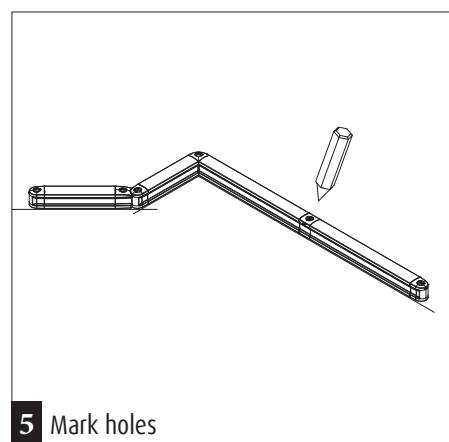
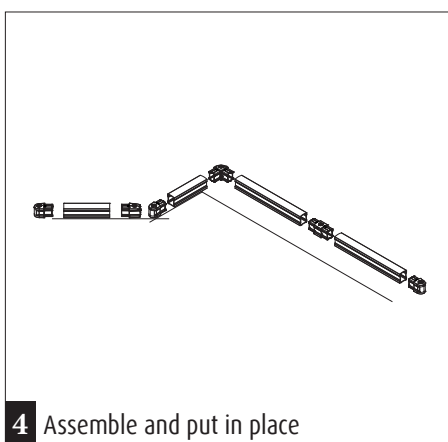
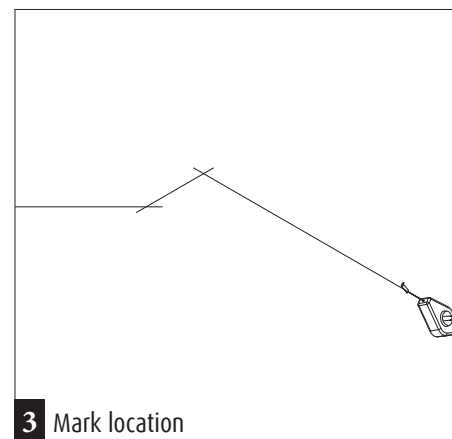
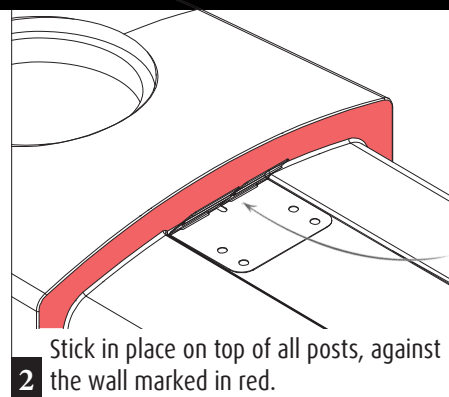
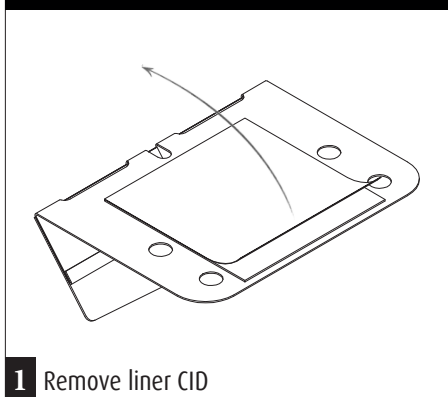

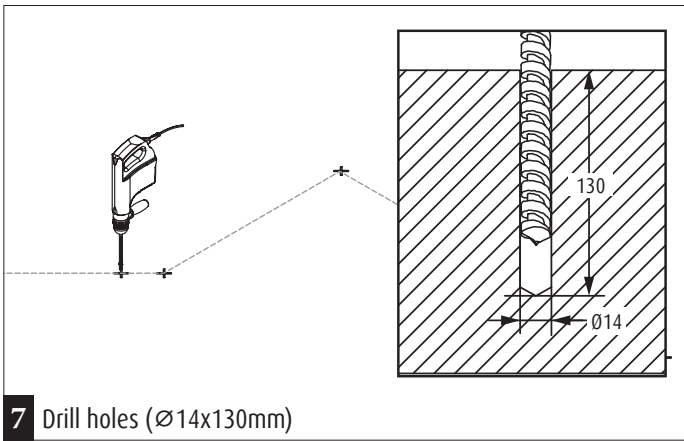

7 Drill holes ($\varnothing 14 \times 130 \text{ mm}$)

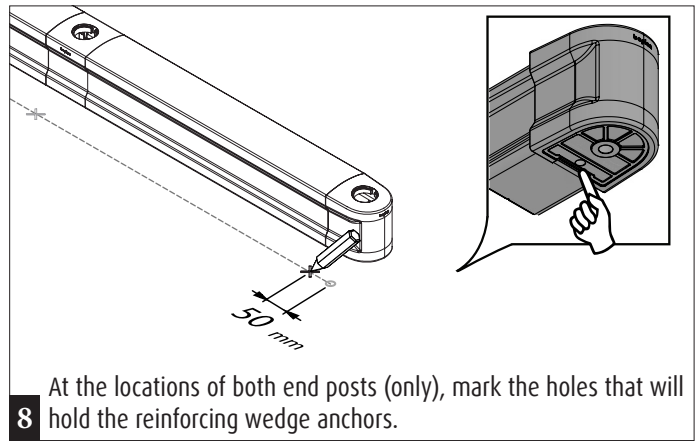

8 At the locations of both end posts (only), mark the holes that will hold the reinforcing wedge anchors.

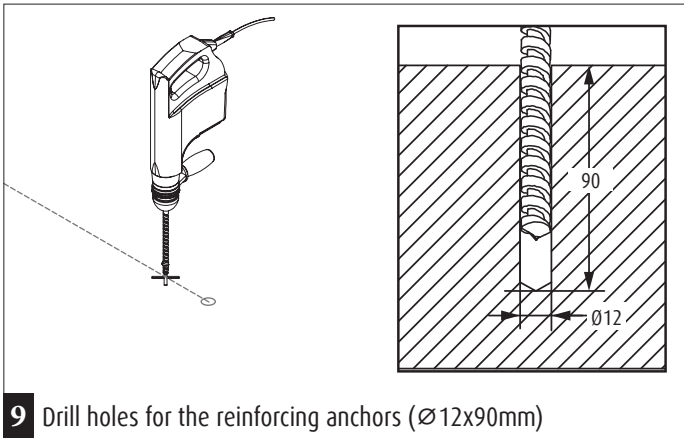

9 Drill holes for the reinforcing anchors ($\varnothing 12 \times 90 \text{ mm}$)

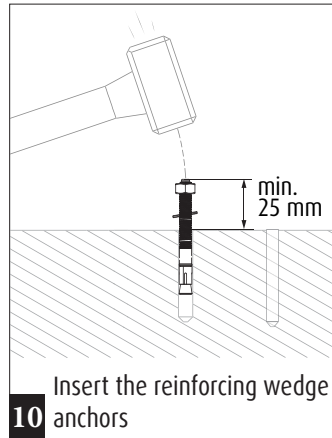

10 Insert the reinforcing wedge anchors

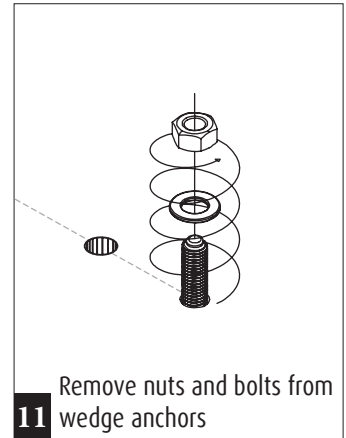

11 Remove nuts and bolts from wedge anchors

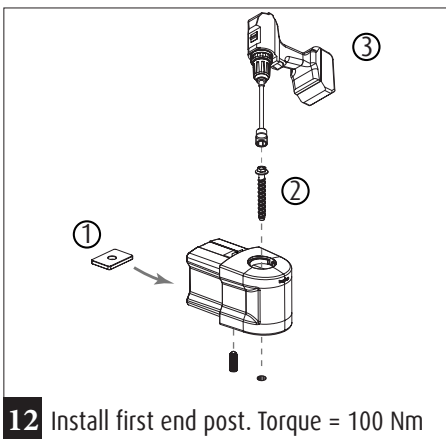

12 Install first end post. Torque = 100 Nm

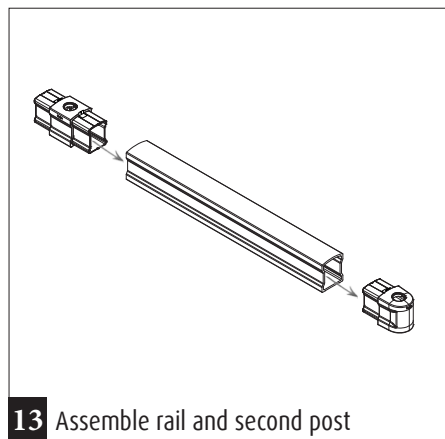

13 Assemble rail and second post

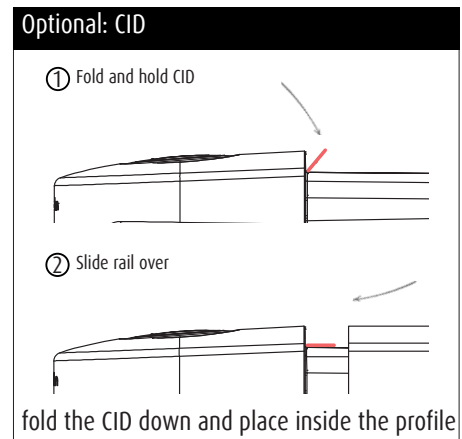

Optional: CID
fold the CID down and place inside the profile

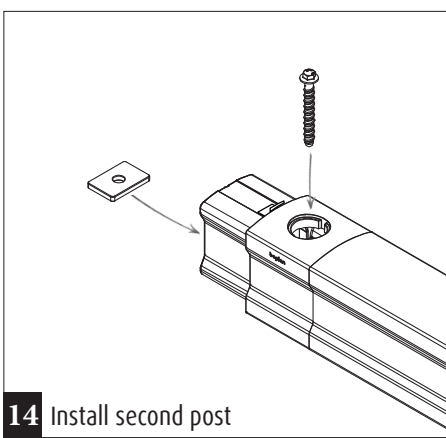

14 Install second post

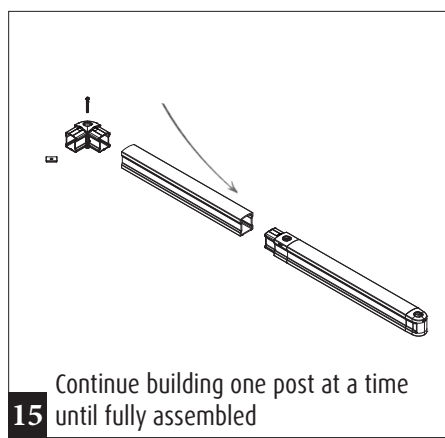

15 Continue building one post at a time until fully assembled

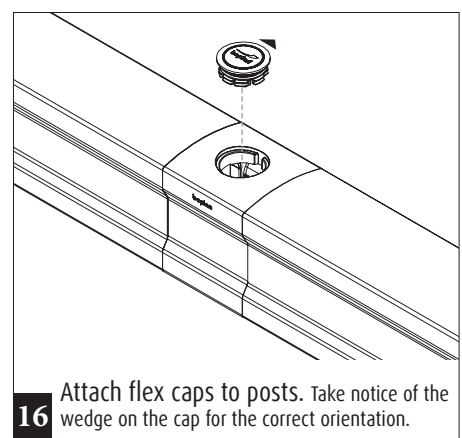

16 Attach flex caps to posts. Take notice of the wedge on the cap for the correct orientation.