

# FLIP120L

## INSTALLATION SHEET

Reference PL1210-...

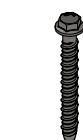

Concrete screw  
( $\varnothing 12.5 \times 100 \text{ mm}$ )

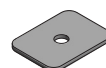

Washer  
( $60 \times 80 \times 4 \text{ mm}$ )



Flex  
Cap



End Cap



Chalk  
line

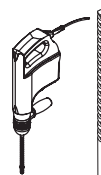

$\varnothing 10 \text{ mm}$

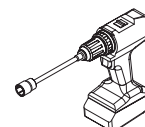
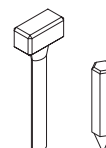

Impact Wrench  
>500 Nm  
+ Extension Part  
+ Socket SW15  
(Preferably magnetic)

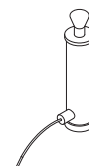

### Required Tools

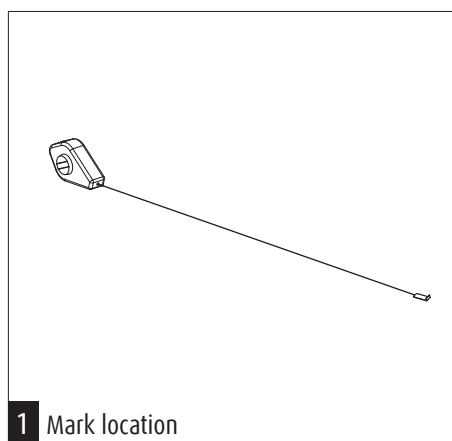

1 Mark location

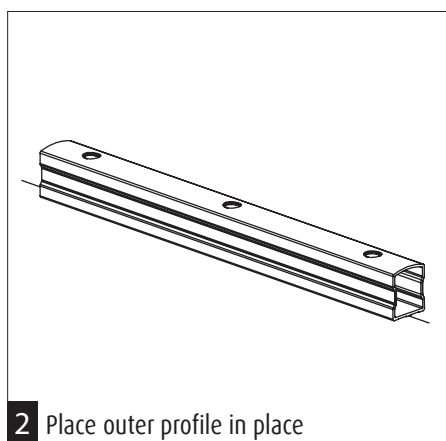

2 Place outer profile in place

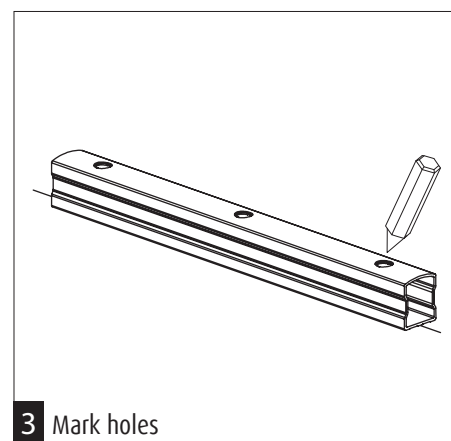

3 Mark holes

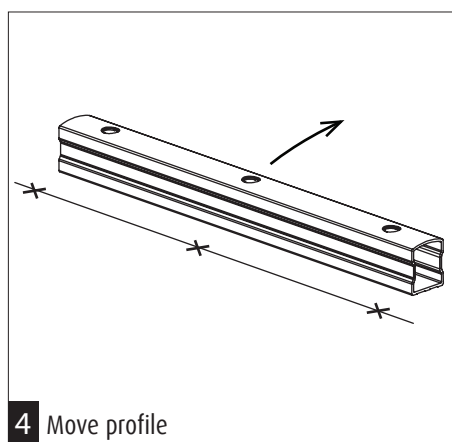

4 Move profile

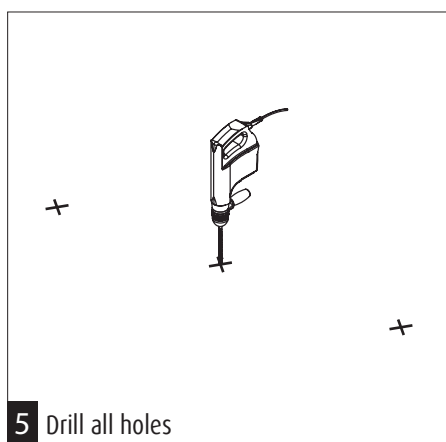

5 Drill all holes

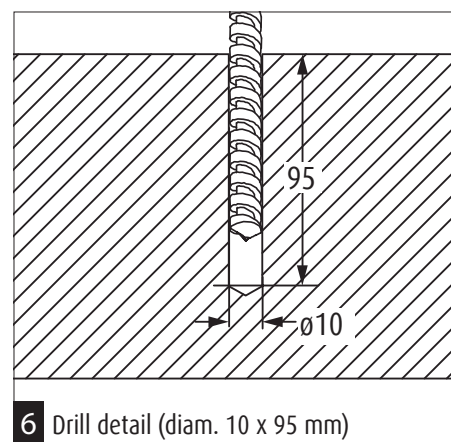

6 Drill detail (diam. 10 x 95 mm)



For more information, please visit [www.boplan.com](http://www.boplan.com)

Rev: 7 November 2024 1:27 pm



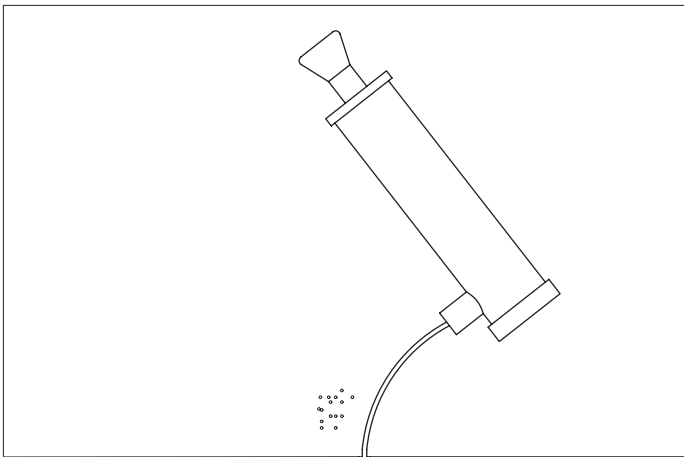

7 Remove dust

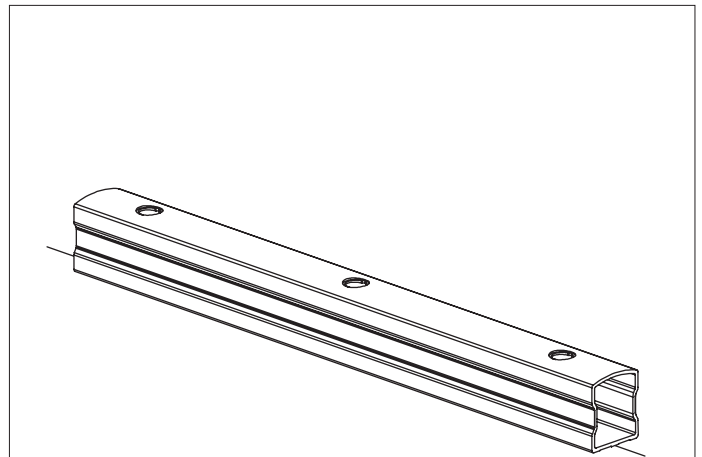

8 Place the profile back in place and align the holes

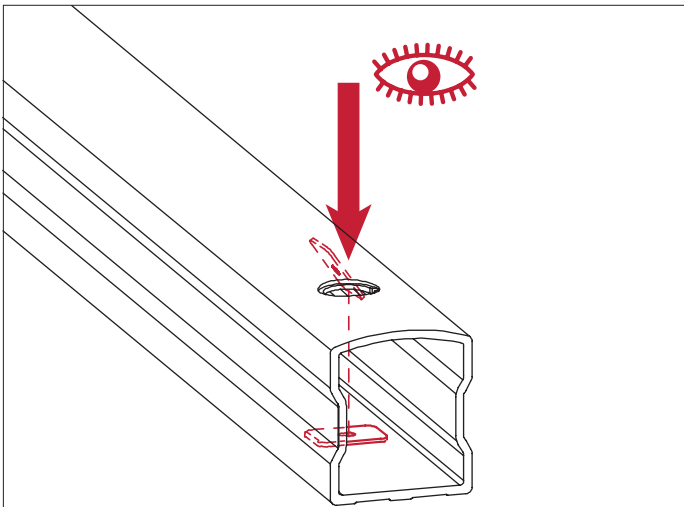

9 Place a washer trough each hole and position correctly

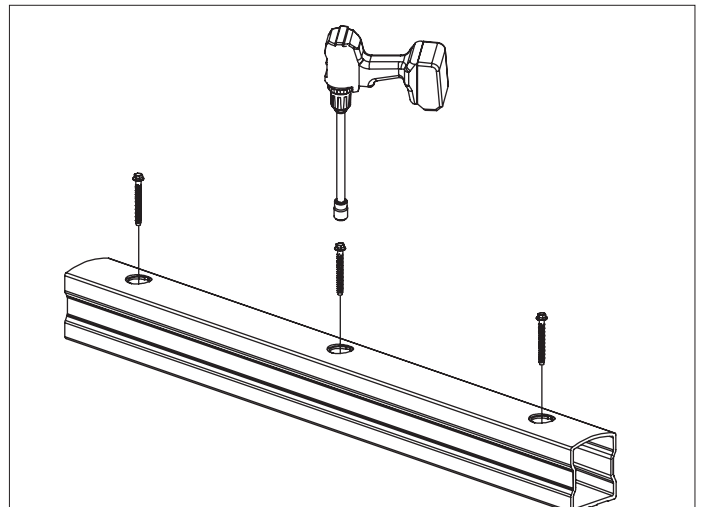

10 Position the screws and tighten with impact wrench.  
Torque = 80 Nm

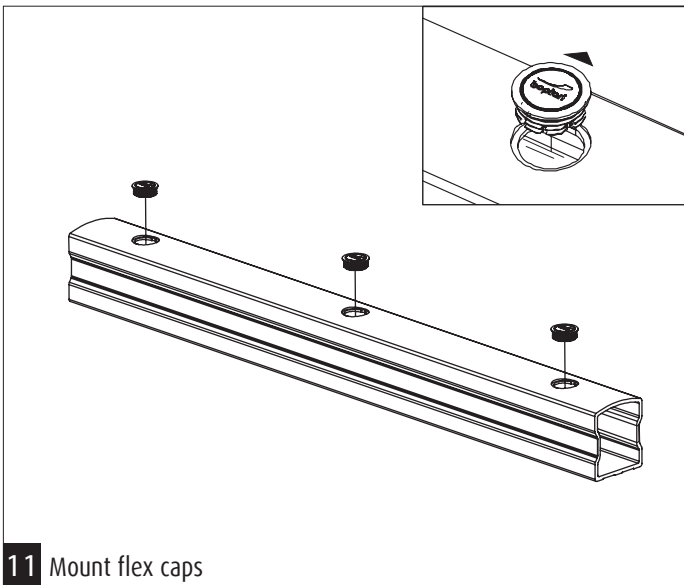

11 Mount flex caps

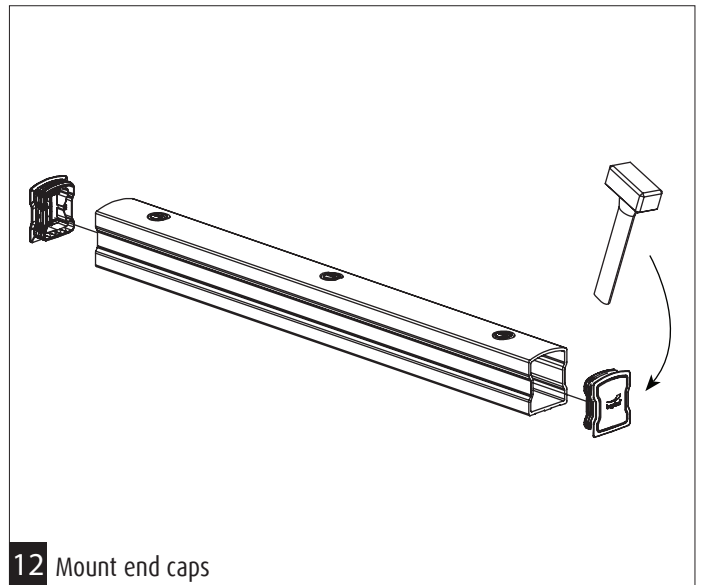

12 Mount end caps



For more information, please visit [www.boplan.com](http://www.boplan.com)

Rev: 7 November 2024 1:27 pm

