

FLIP200F PLUS

INSTALLATION SHEET

Reference: PL2300-...

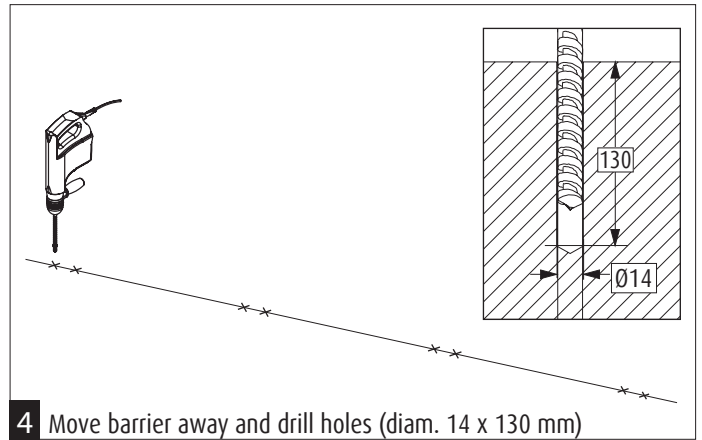

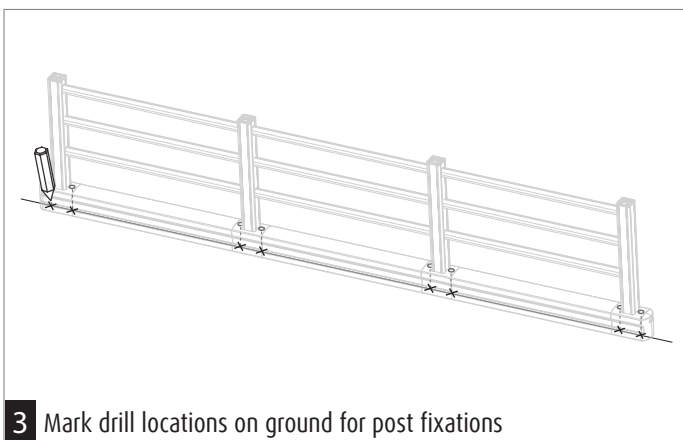
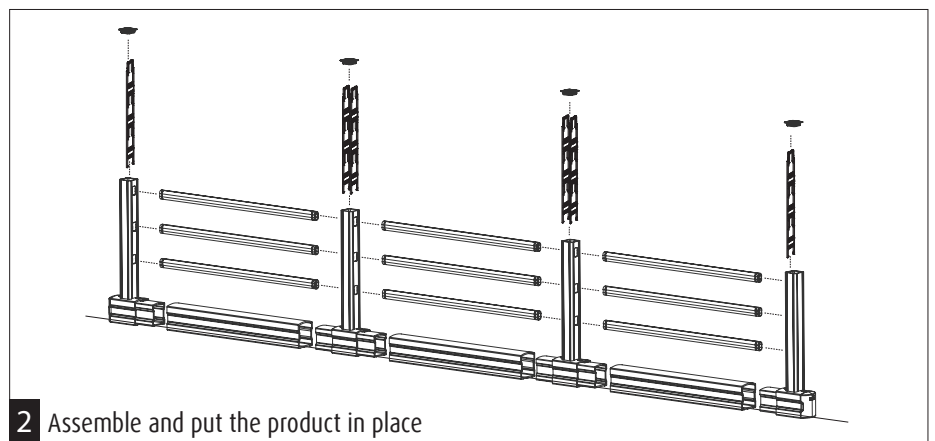
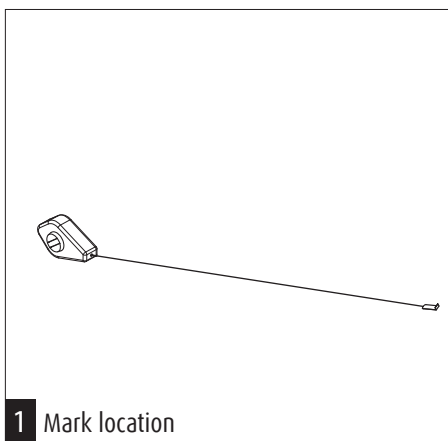
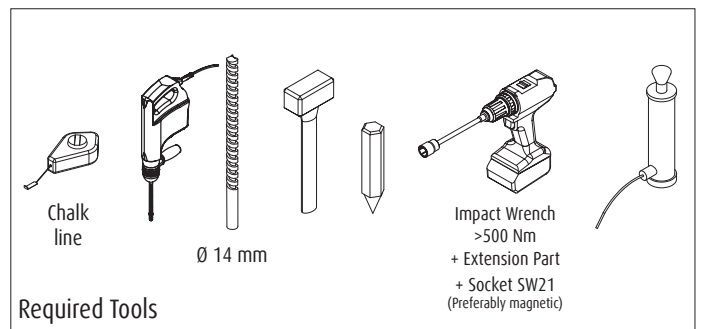
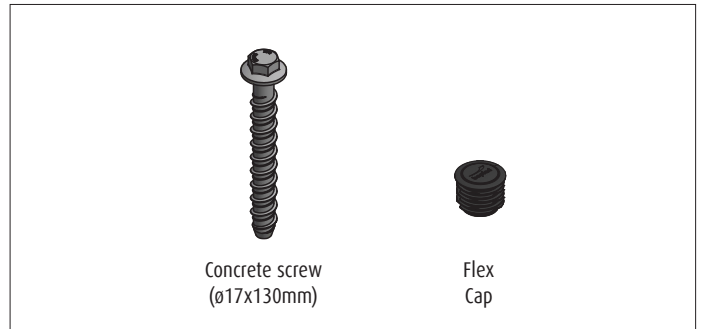
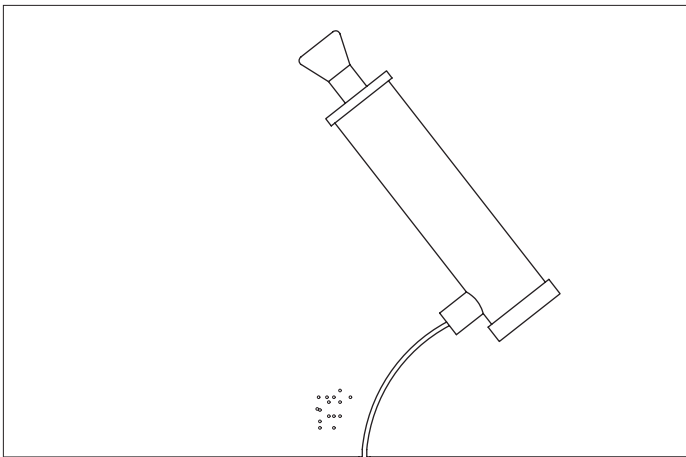

5 Remove dust

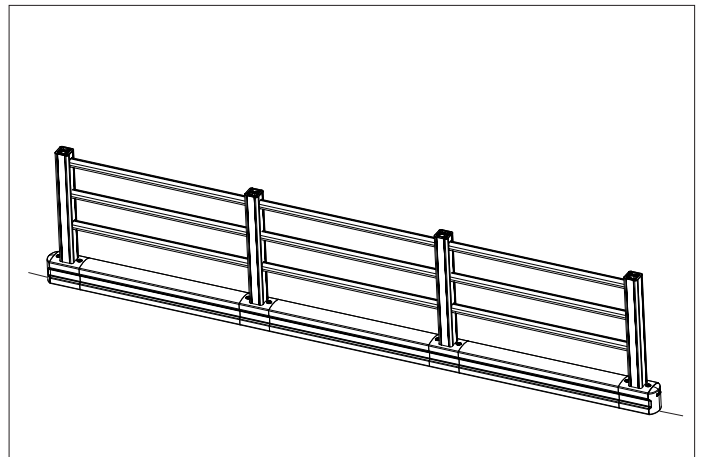

6 Put product back in place and align the holes

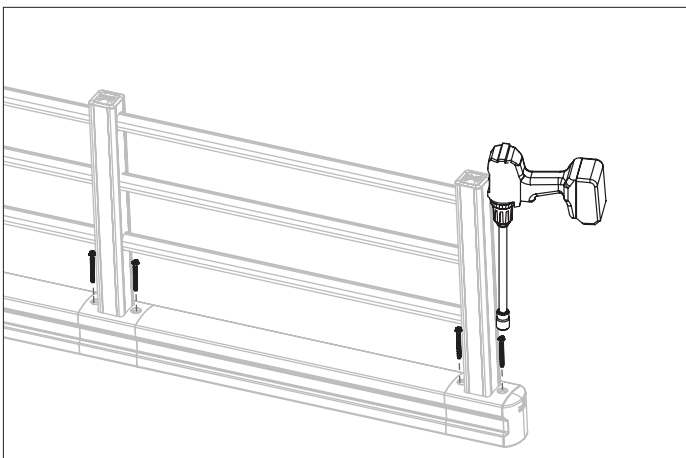

7 Position the screws and tighten with impact wrench.
Torque = 100 Nm

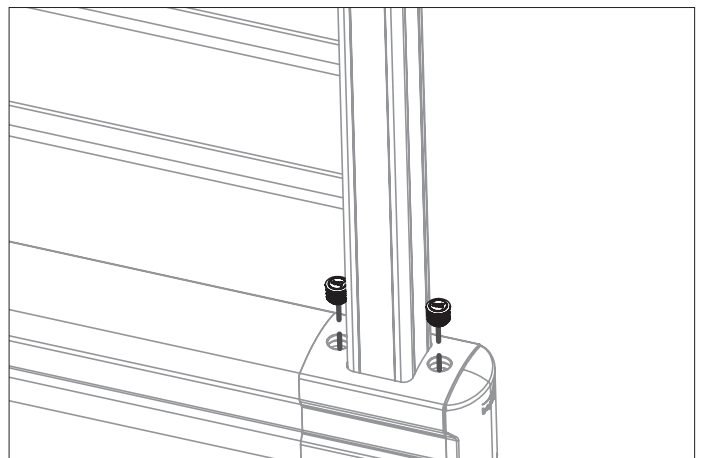

8 Mount flex caps in holes on each post

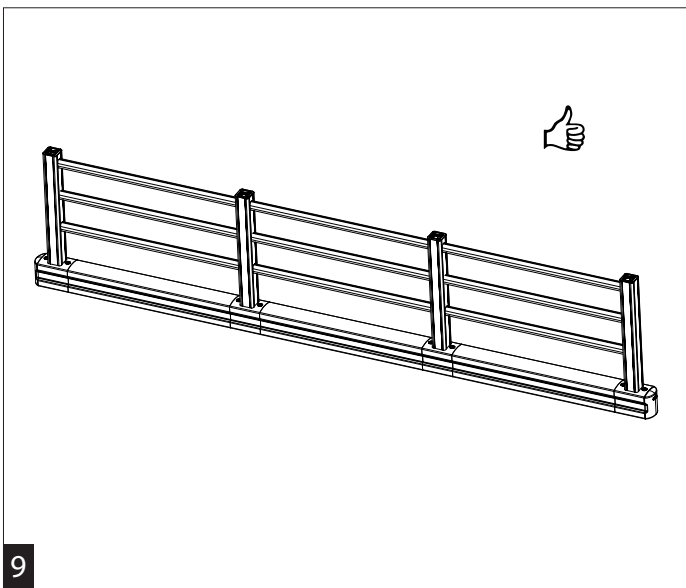

9