

# DOCK GATE 250F/R

## INSTALLATION SHEET

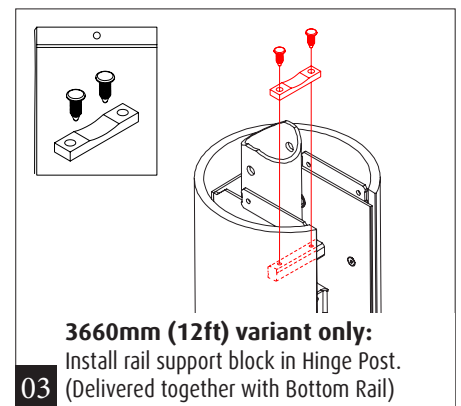

Product ref.: DG250F0-... / DG250R0-...

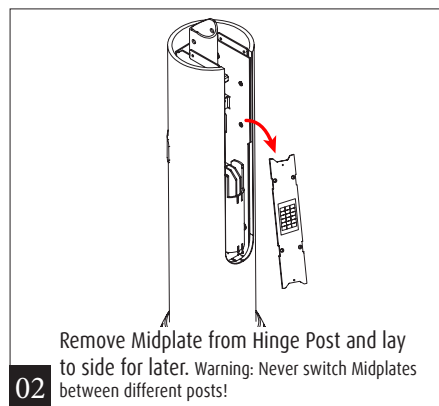
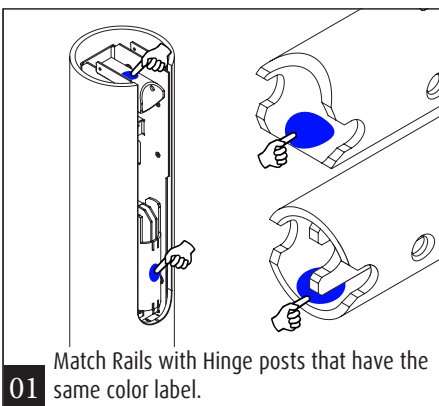
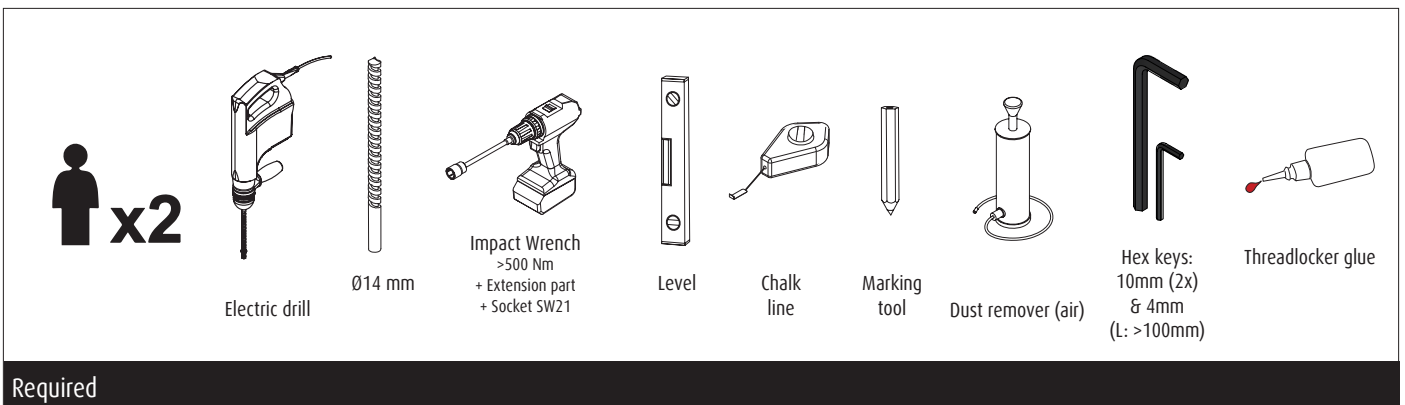

For more information, please visit [www.boplan.com](http://www.boplan.com)

Doc ref. : XMA-0001-DG250FR

Rev: 14 March 2025 3:44 pm

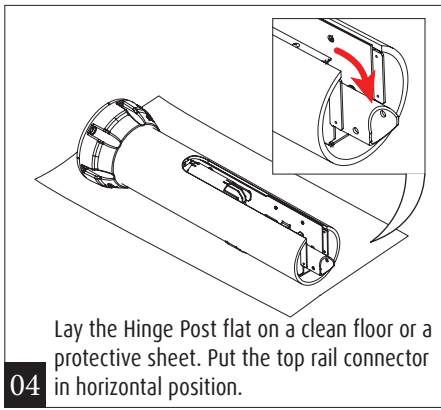

Lay the Hinge Post flat on a clean floor or a protective sheet. Put the top rail connector in horizontal position.

04

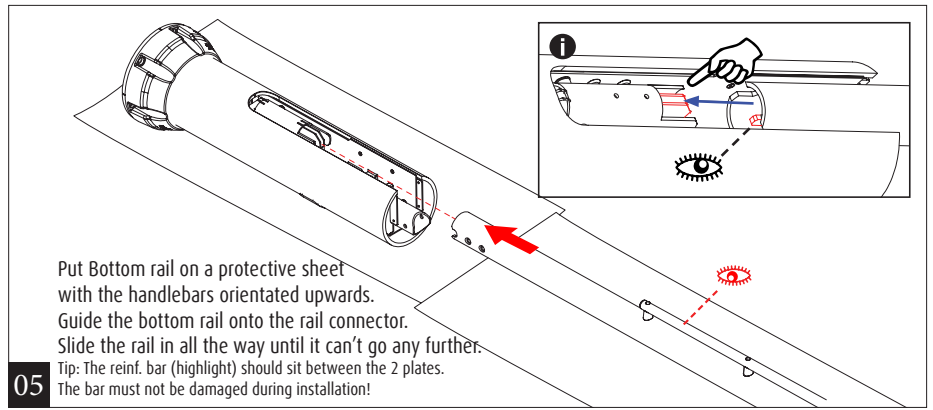

Put Bottom rail on a protective sheet with the handlebars orientated upwards. Guide the bottom rail onto the rail connector. Slide the rail in all the way until it can't go any further.  
Tip: The reinf. bar (highlight) should sit between the 2 plates. The bar must not be damaged during installation!

05

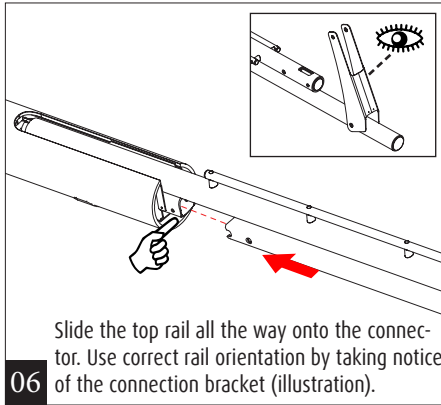

Slide the top rail all the way onto the connector. Use correct rail orientation by taking notice of the connection bracket (illustration).

06

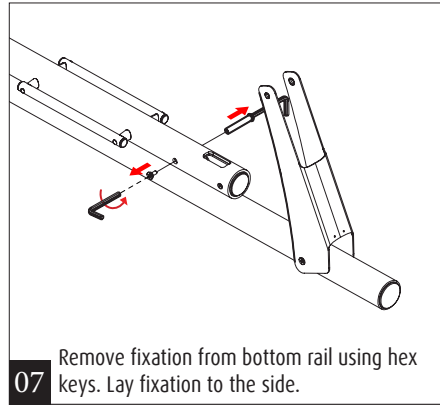

Remove fixation from bottom rail using hex keys. Lay fixation to the side.

07

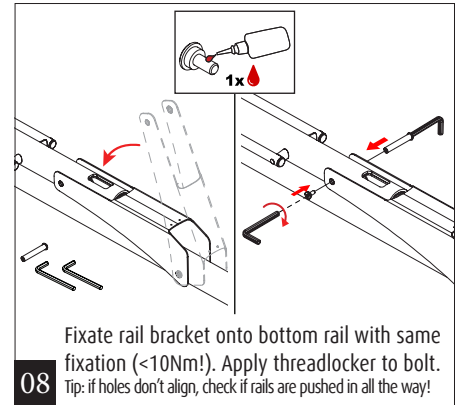

Fixate rail bracket onto bottom rail with same fixation (<10Nm!). Apply threadlocker to bolt.  
Tip: If holes don't align, check if rails are pushed in all the way!

08

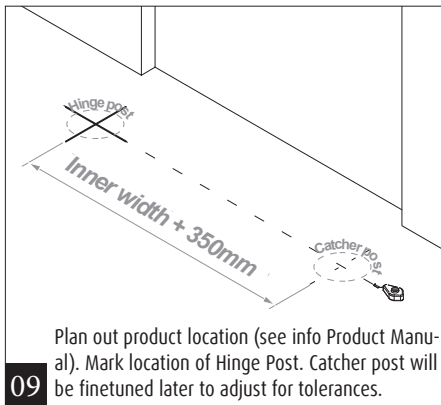

Plan out product location (see info Product Manual). Mark location of Hinge Post. Catcher post will be finetuned later to adjust for tolerances.

09

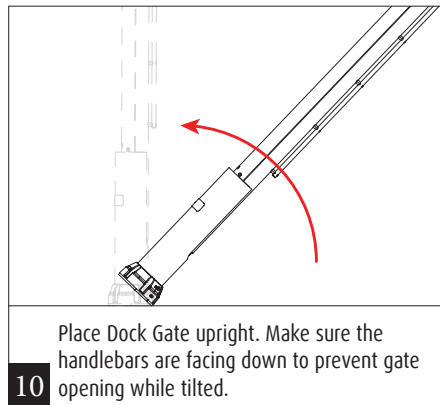

Place Dock Gate upright. Make sure the handlebars are facing down to prevent gate opening while tilted.

10

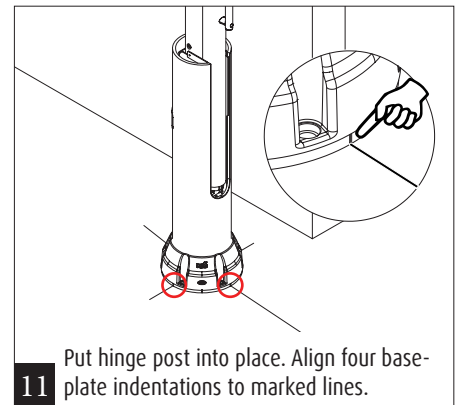

Put hinge post into place. Align four base-plate indentations to marked lines.

11

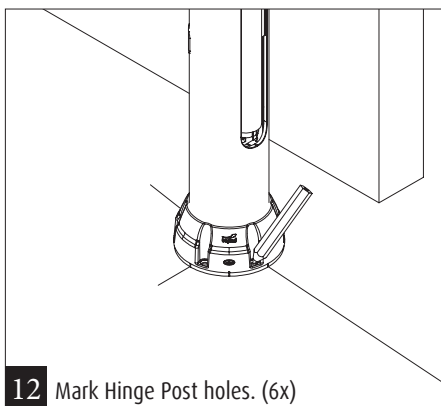

12 Mark Hinge Post holes. (6x)

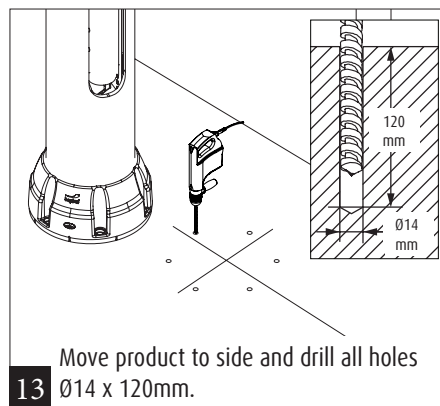

Move product to side and drill all holes  $\text{Ø}14 \times 120\text{mm}$ .

13

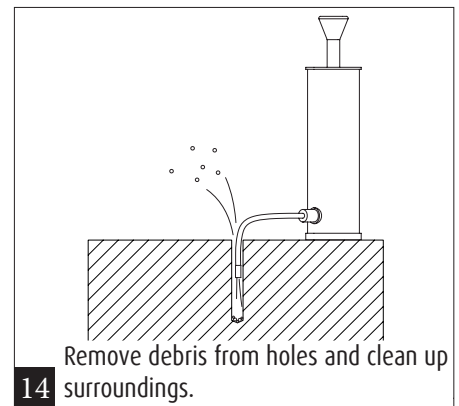

Remove debris from holes and clean up surroundings.

14

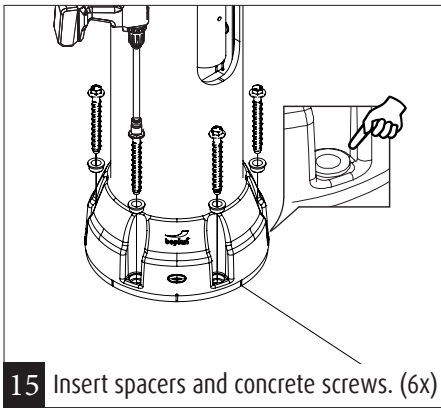

**15** Insert spacers and concrete screws. (6x)

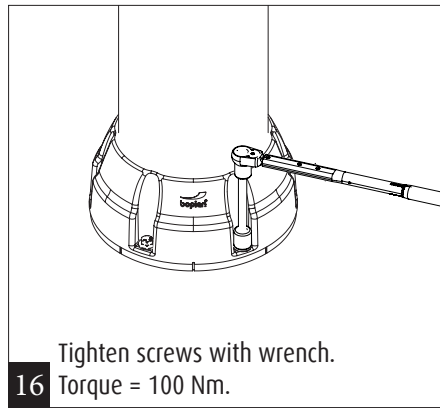

**16** Tighten screws with wrench.  
Torque = 100 Nm.

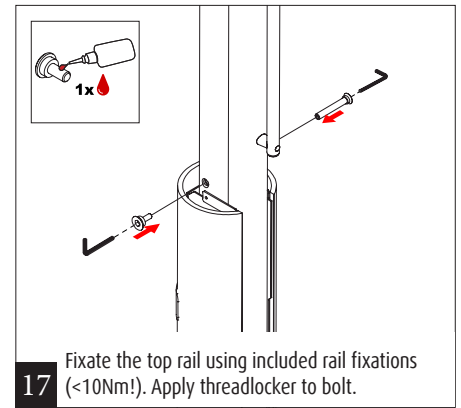

**17** Fixate the top rail using included rail fixations (<10Nm!). Apply threadlocker to bolt.

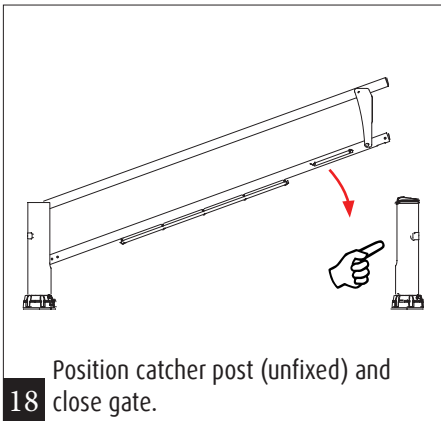

**18** Position catcher post (unfixed) and close gate.

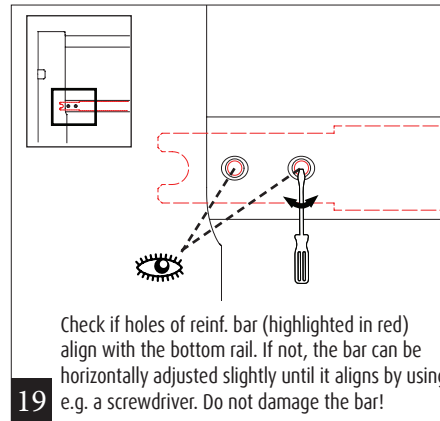

**19** Check if holes of reinf. bar (highlighted in red) align with the bottom rail. If not, the bar can be horizontally adjusted slightly until it aligns by using e.g. a screwdriver. Do not damage the bar!

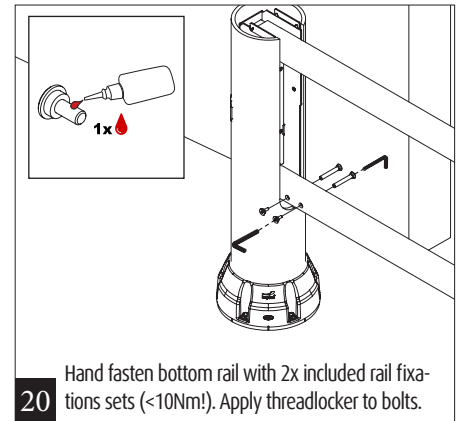

**20** Hand fasten bottom rail with 2x included rail fixations sets (<10Nm!). Apply threadlocker to bolts.

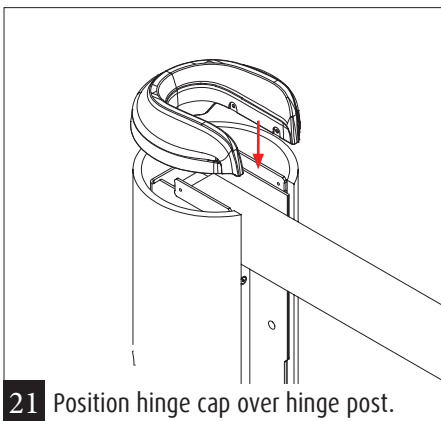

**21** Position hinge cap over hinge post.

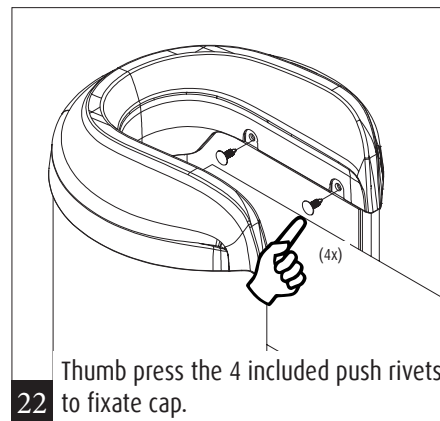

**22** Thumb press the 4 included push rivets to fixate cap.

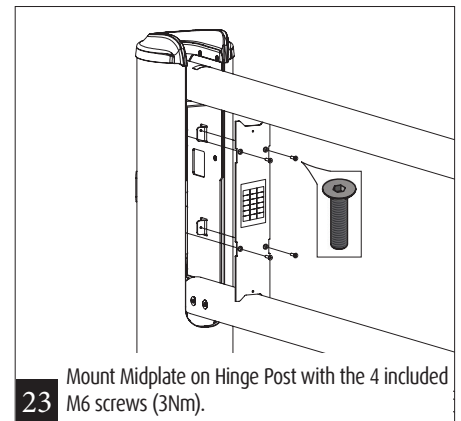

**23** Mount Midplate on Hinge Post with the 4 included M6 screws (3Nm).

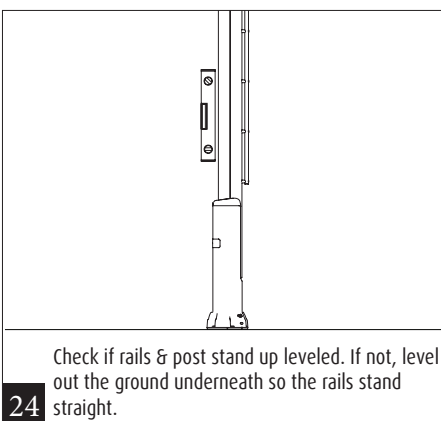

**24** Check if rails & post stand up leveled. If not, level out the ground underneath so the rails stand straight.

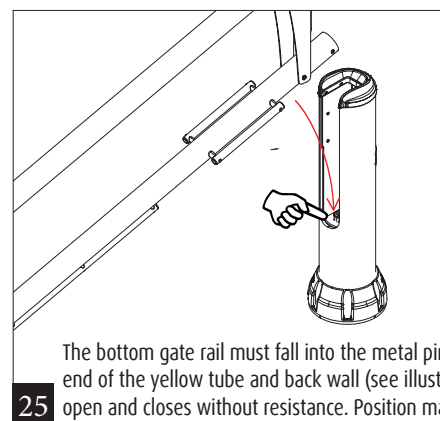

**25** The bottom gate rail must fall into the metal pin of the Catcher Post. Leave a 15-18 mm gap between the end of the yellow tube and back wall (see illustration). Keep adjusting the Catcher post position until gate open and closes without resistance. Position may differ from initial marked location due to tolerances.

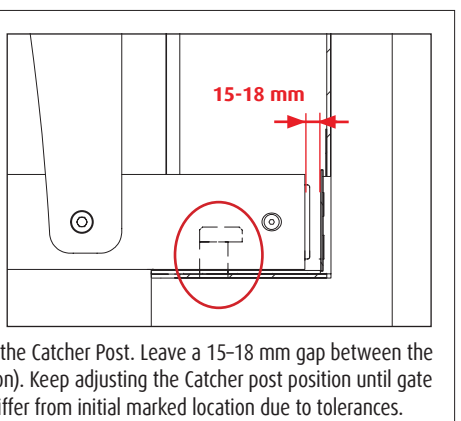

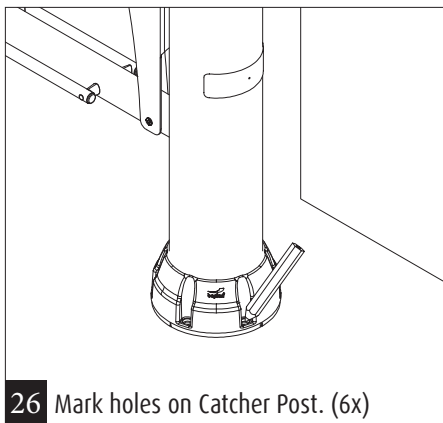

**26** Mark holes on Catcher Post. (6x)

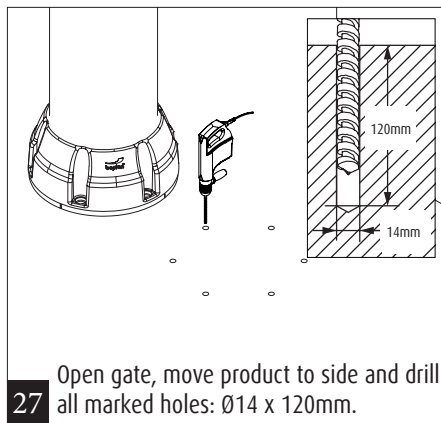

**27** Open gate, move product to side and drill all marked holes: Ø14 x 120mm.

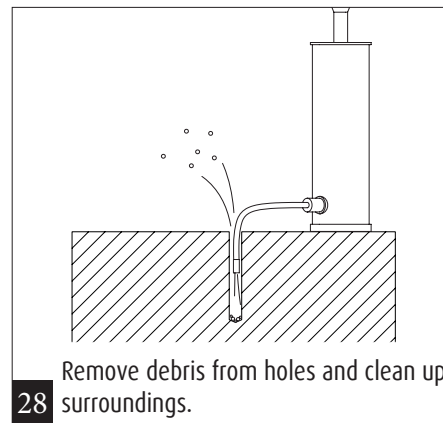

**28** Remove debris from holes and clean up surroundings.

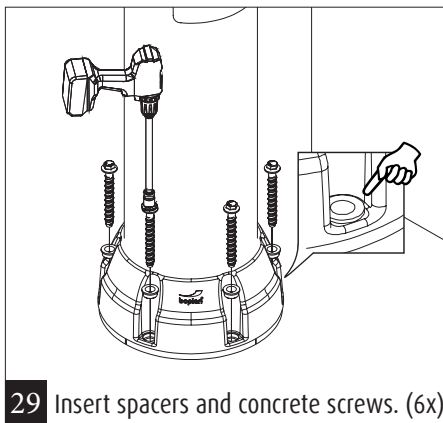

**29** Insert spacers and concrete screws. (6x)

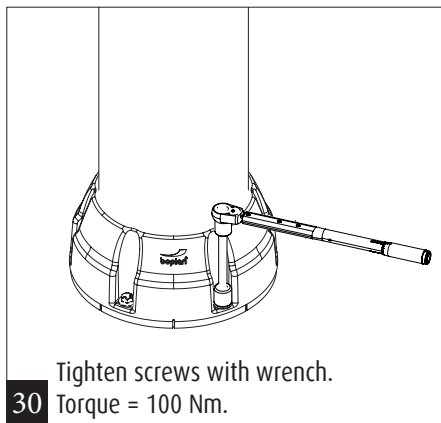

**30** Tighten screws with wrench.  
Torque = 100 Nm.

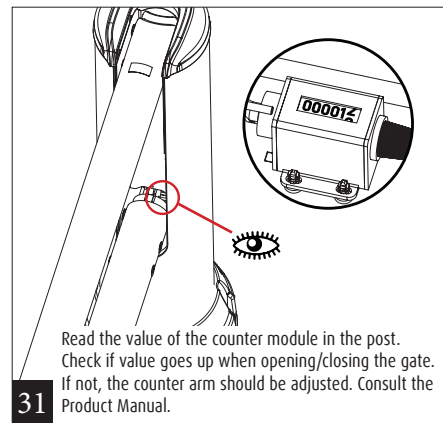

**31** Read the value of the counter module in the post. Check if value goes up when opening/closing the gate. If not, the counter arm should be adjusted. Consult the Product Manual.

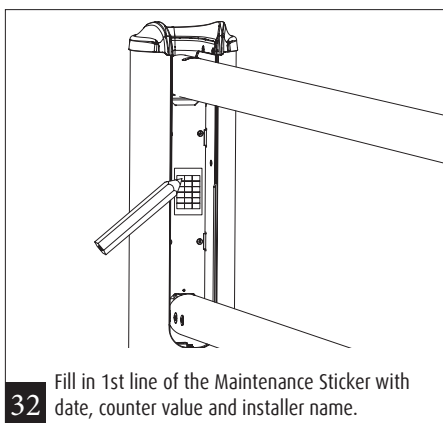

**32** Fill in 1st line of the Maintenance Sticker with date, counter value and installer name.

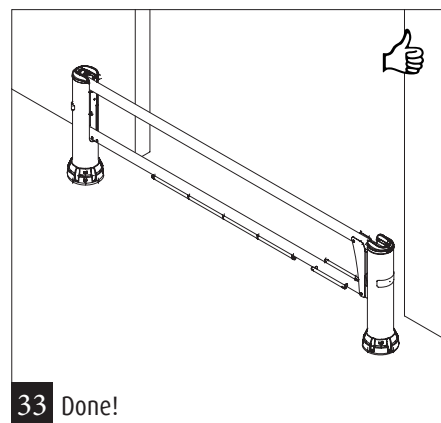

**33** Done!

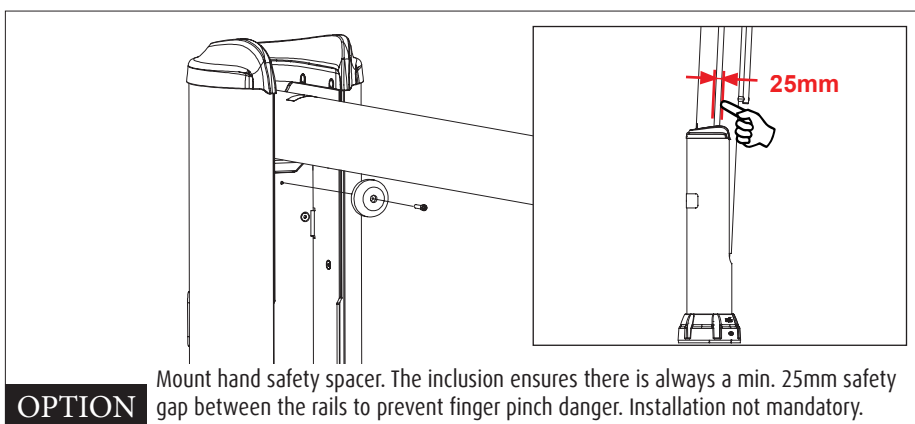

**OPTION** Mount hand safety spacer. The inclusion ensures there is always a min. 25mm safety gap between the rails to prevent finger pinch danger. Installation not mandatory.