

# FLIP200F

## INSTALLATION SHEET

Reference: PL202...

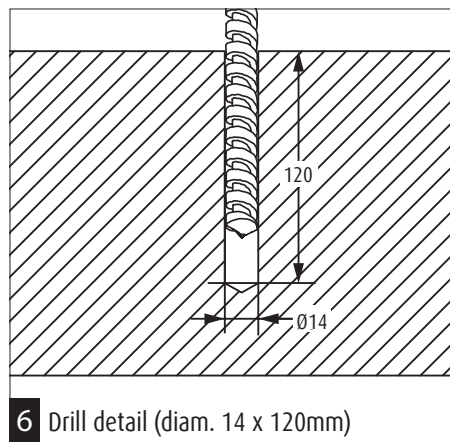

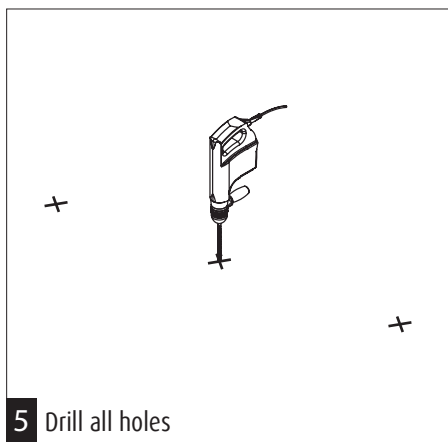
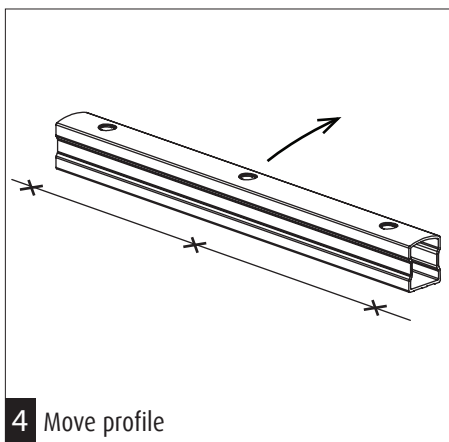
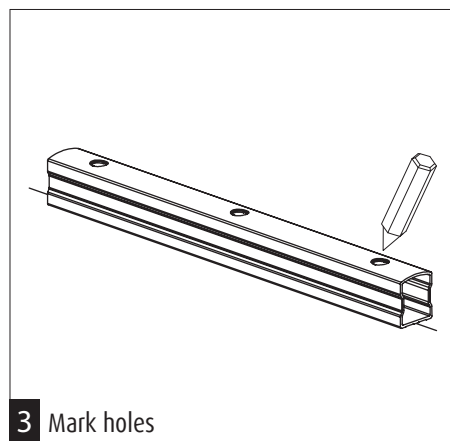
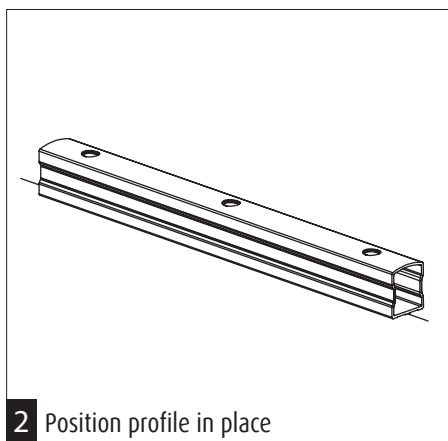
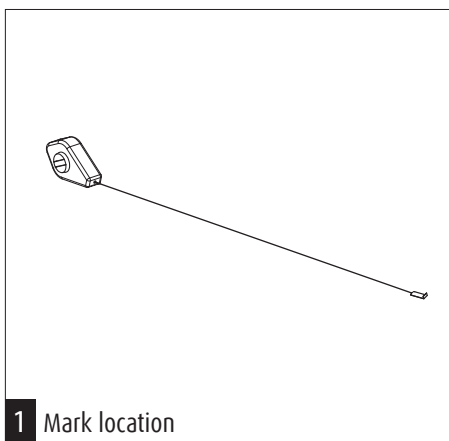
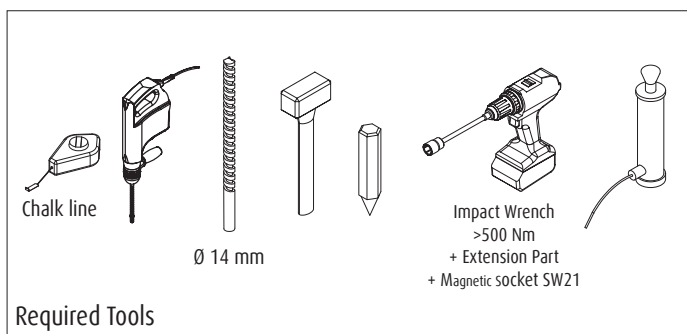
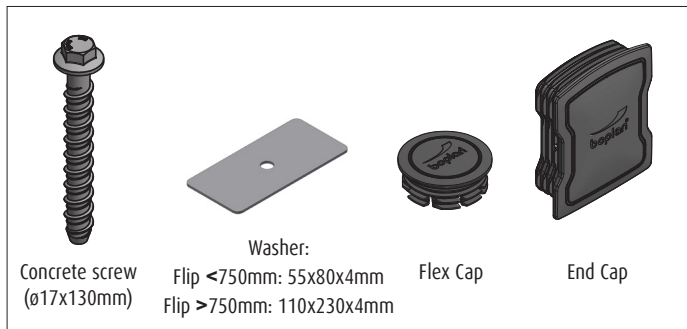
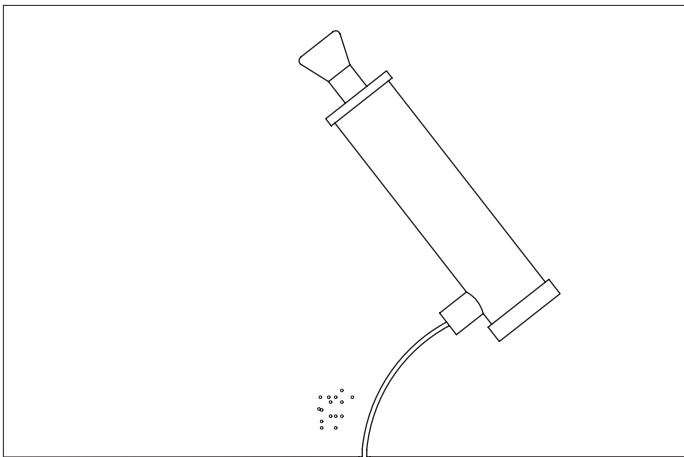

7 Remove dust

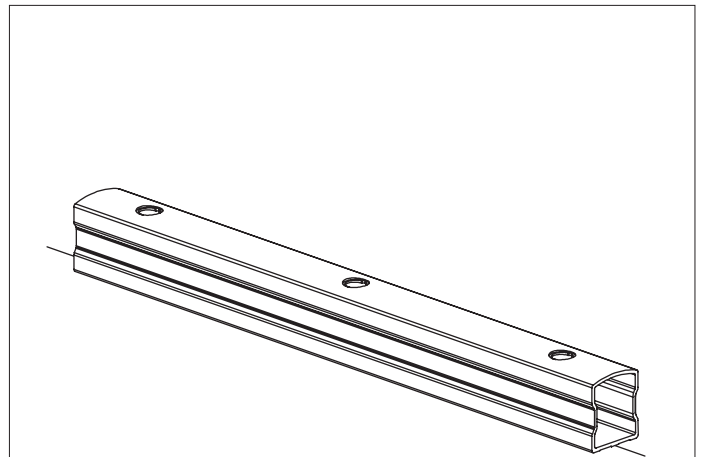

8 Place the profile back in place and align the holes

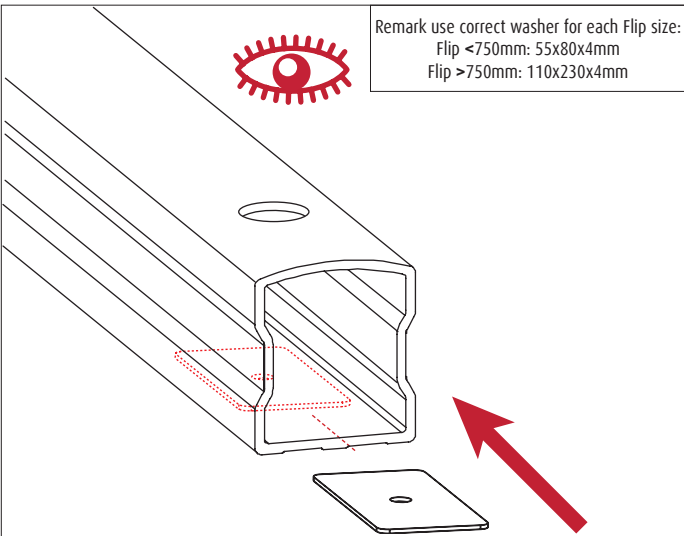

9 Place a washer trough the sides and position correctly

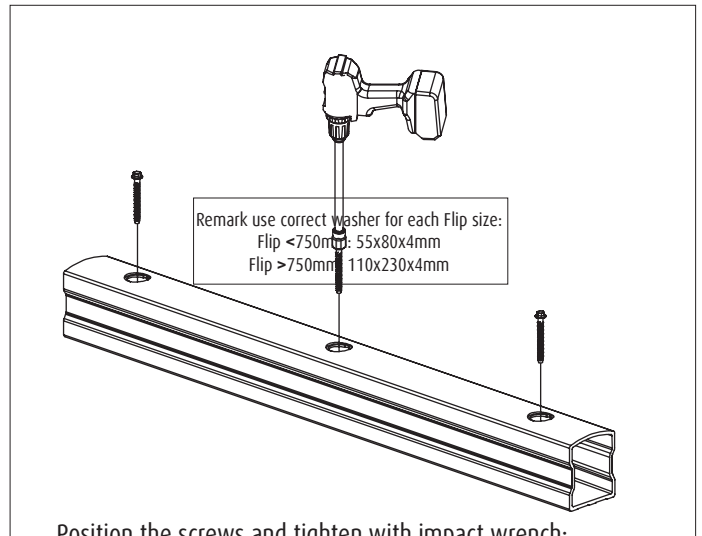

10 Position the screws and tighten with impact wrench;  
Torque = 100 Nm

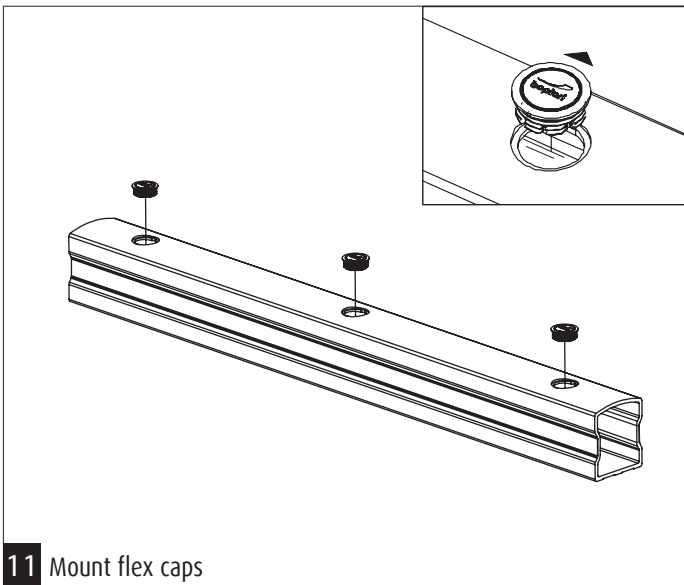

11 Mount flex caps

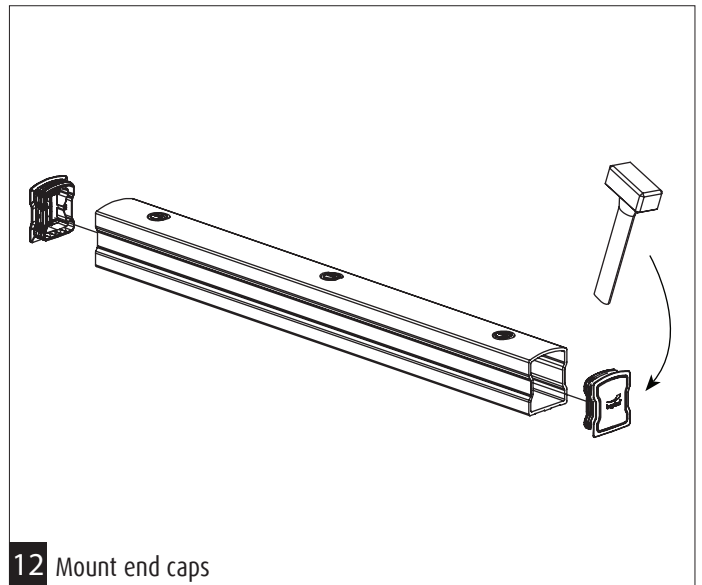

12 Mount end caps