

BO125L EV

BOLLARDS AND HEIGHT LIMITERS

Revision: 17 June 2024 9:25 AM
Boplan reference: BO125L0-...



PRODUCT SPECIFICATIONS

APPLICATION	
Environment	The BO125L EV helps prevent accidents, minimizes damage, and maintains safe accessibility to electric mobility. With their visibility and impact-resistant flexibility, EV-bollards are the most effective solution for the protection of charging stations against potential vehicle impacts.
Impact performance	500 Joule (Eq. to 4000 lbs - 1.5 mph)
OPTIONAL	
Stripes	Colored reflective stripes providing a high level of visibility.
MATERIAL	
Tube & Cover	Extrilene® - UV resistant - Fire class E* - Non conductive - Impervious to most chemicals***
Cap	Sustainable elastomer
STANDARD COLORS	
Bollard	Standard: Black RAL 9005 Also available in Yellow RAL 1003 and White RAL 9003 (Multicolor)
Cover	Standard: Black RAL 9005
BASEPLATES	
	Zinc Coated Steel
Material	Steel 37
Coating	Electroplated + Lacquered
Color	Mat black

*Classification according to EN 13501-1:2007 +A1:2009 - Fire classification of construction products and building elements.

**Ask your local sales office for resistance to specific chemicals.

FIXATIONS		ZC (Zinc coated)	SS (Stainless steel)
STANDARD	Anchor rod (Chemical)	M12 x 120mm + Chemical resin	M12 x 120mm + Chemical resin











































FEATURES AND FUNCTIONALITY - B0125L EV

SIZE	
Height	30 inch 40 inch
Profile section post	Ø5 inch (0.4 inch thick)
Baseplate	Ø5 inch (0.3 inch thick)
Base Cover	Diameter: Ø5.7 inch Height: 3.1 inch

REQUIREMENTS	
Concrete quality	minimum C25/30
Concrete floor plate thickness (in)	minimum 5.9 inch
Concrete slab dimension around posts (in)	15.7 (h) x 15.7 (w) x 11.8 (d)
Operational temperature	14 °F up to 104 °F
Water and humidity	Zinc coated: Indoor and outdoor use in most environments.



IMPACT LABEL FOR SAFETY BARRIERS

BOPLAN B0125L EV																									
IMPACT RATING																									
<table border="0" style="width: 100%;"> <tr><td></td><td>< 11 kJ</td></tr> <tr><td></td><td>< 10 kJ</td></tr> <tr><td></td><td>< 9.0 kJ</td></tr> <tr><td></td><td>< 8.0 kJ</td></tr> <tr><td></td><td>< 7.0 kJ</td></tr> <tr><td></td><td>< 6.0 kJ</td></tr> <tr><td></td><td>< 5.0 kJ</td></tr> <tr><td></td><td>< 4.0 kJ</td></tr> <tr><td></td><td>< 3.0 kJ</td></tr> <tr><td></td><td>< 2.0 kJ</td></tr> <tr><td></td><td>< 1.0 kJ</td></tr> <tr><td></td><td>< 0.5 kJ</td></tr> </table>		< 11 kJ		< 10 kJ		< 9.0 kJ		< 8.0 kJ		< 7.0 kJ		< 6.0 kJ		< 5.0 kJ		< 4.0 kJ		< 3.0 kJ		< 2.0 kJ		< 1.0 kJ		< 0.5 kJ	
	< 11 kJ																								
	< 10 kJ																								
	< 9.0 kJ																								
	< 8.0 kJ																								
	< 7.0 kJ																								
	< 6.0 kJ																								
	< 5.0 kJ																								
	< 4.0 kJ																								
	< 3.0 kJ																								
	< 2.0 kJ																								
	< 1.0 kJ																								
	< 0.5 kJ																								
IMPACT RESULTS Deflection: At maximum impact energy  $\alpha = 15.7^\circ$ $D = 213 \text{ mm} / 8 \text{ 3/8 inch}$	SUCCESS CRITERIA VEHICLE STOPPED ASI (ACCELERATION SEVERITY INDEX) < 0.5																								
TEST CONDITIONS TEMPERATURE: 20°C / 68°F IMPACT HEIGHT: 450 mm / 17 5/8 Inch → D: 213 mm / 8 3/8 Inch → $\alpha: 15.7^\circ$ TEST FLOOR: CONCRETE SLAB C25/30 - 150 mm / 6 Inch	BOPLAN TEST LAB Muizelstraat 12 8560 Moorsele Belgium 																								
TEST VEHICLE: TYPE: BOPLAN IMPACT TEST VEHICLE WEIGHT: 3775 Kg / 8322.45 lbs SIZE (L x W x H): 3100 x 1100 x 1150 mm / 122 x 43 1/4 x 45 1/4 Inch CONTACT AREA, STEEL BUMPER WIDTH: 1000 mm / 39 1/4 Inch	IL-B0125LEV-20240131																								

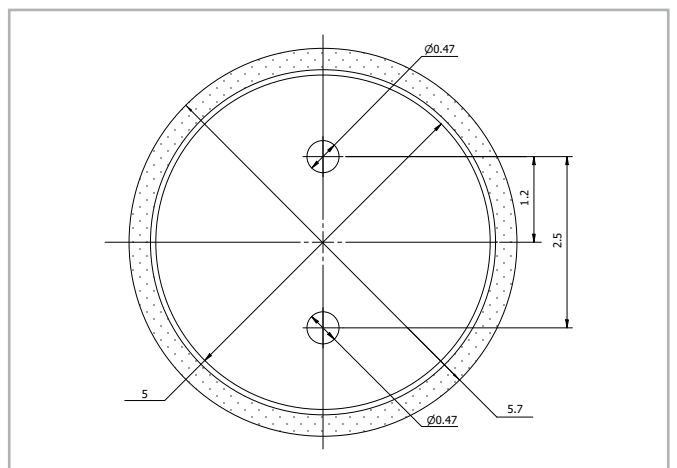
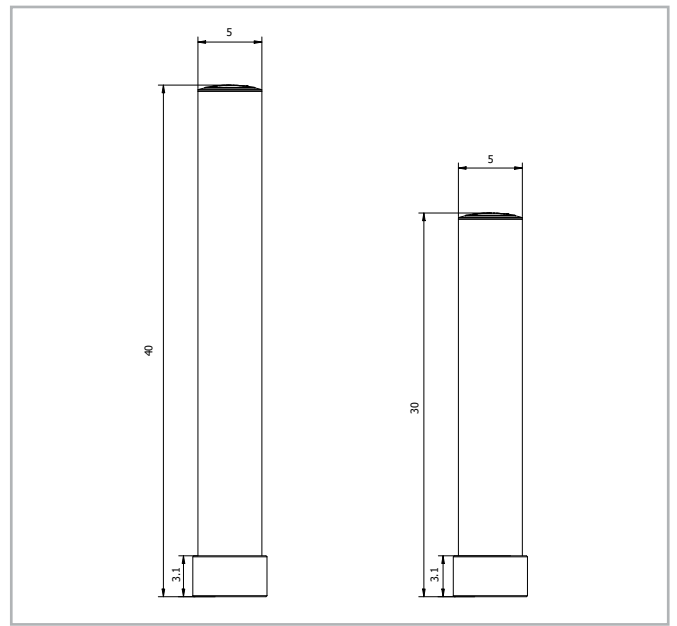

REFERENCE LIST - B0125L EV

	ZINC COATED (ZC) Non - countersunk	
	BLACK	MULTICOLOR <input type="checkbox"/> <input type="checkbox"/>
40 inch	B0125L0-1000-01EVBL	B0125L0-1000-01EVMC
30 inch	B0125L0-0750-01EVBL	B0125L0-0750-01EVMC

STRIPES			
	Black	White	Yellow
1 STRIPE	PA0300-0125-0001BL	PA0300-0125-0001WH	PA0300-0125-0001YE
			

* Remark: Stripes cannot be ordered separately