

# FLIP 180B

## INSTALLATION SHEET

Reference: PL181B...

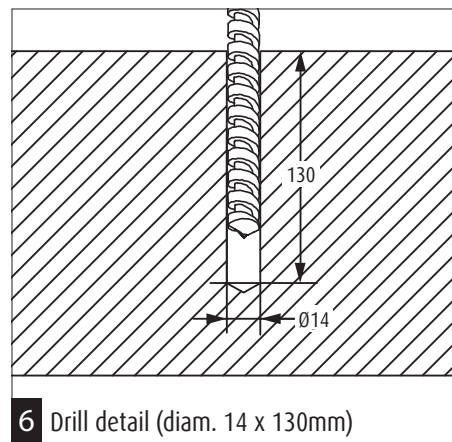

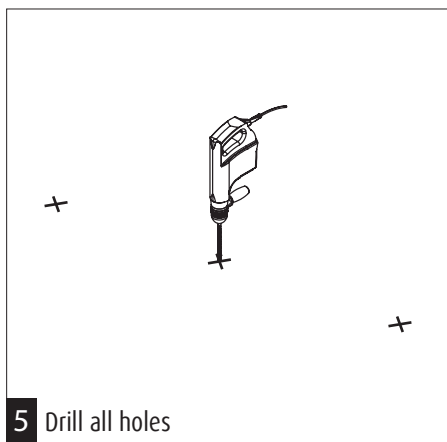
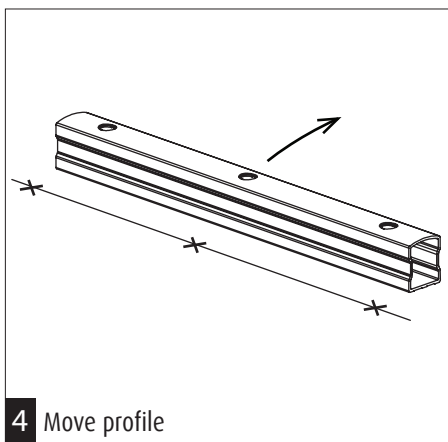
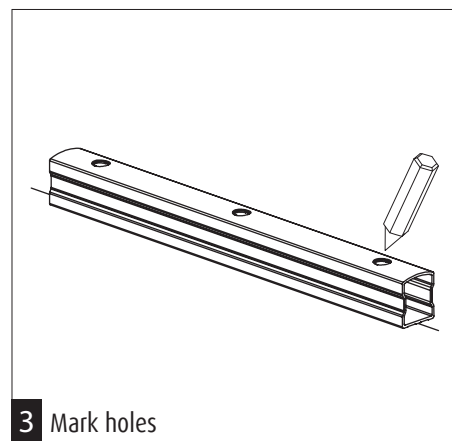
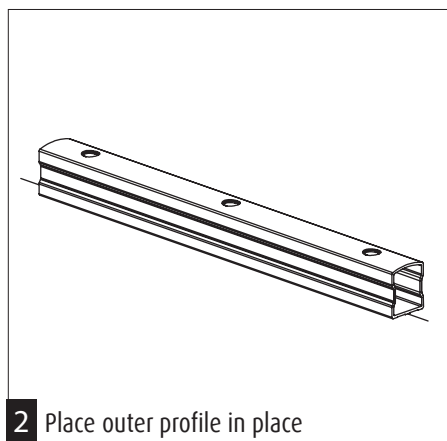
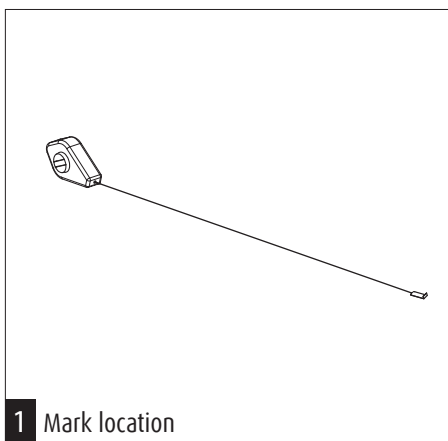
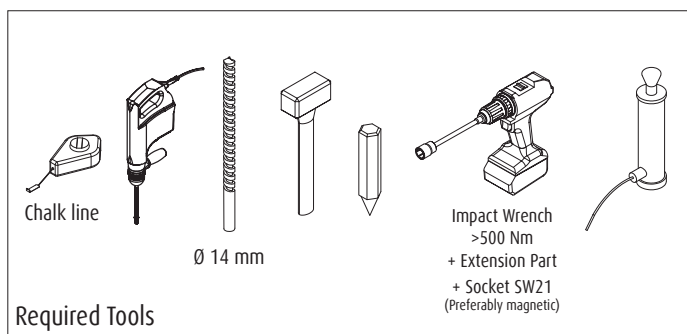
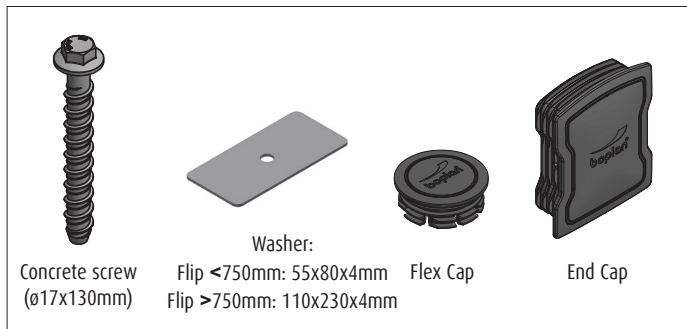
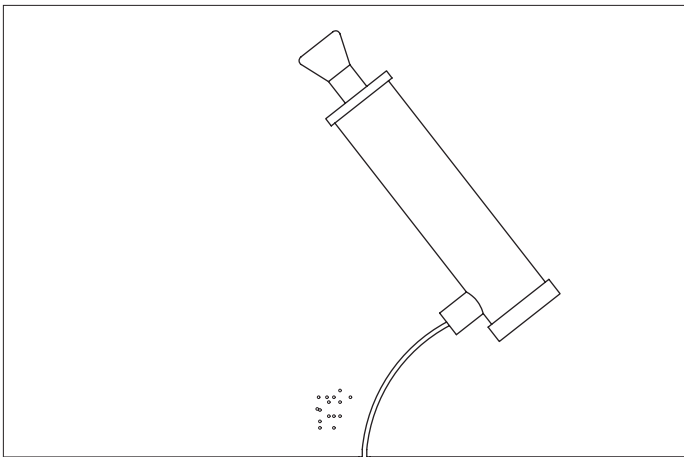

**7** Remove dust

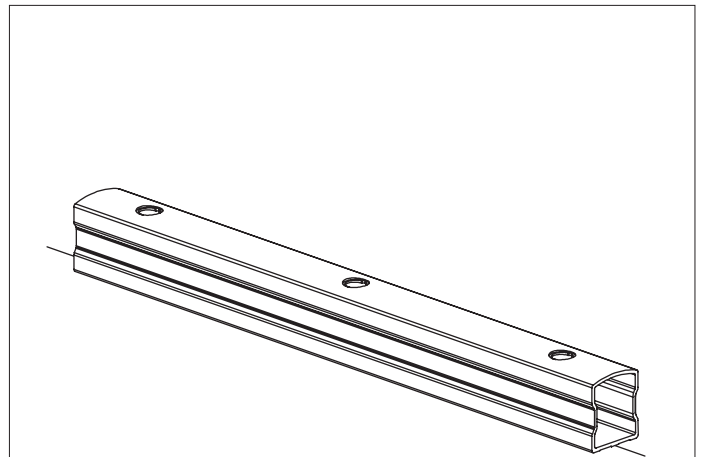

**8** Place the profile back in place and align the holes

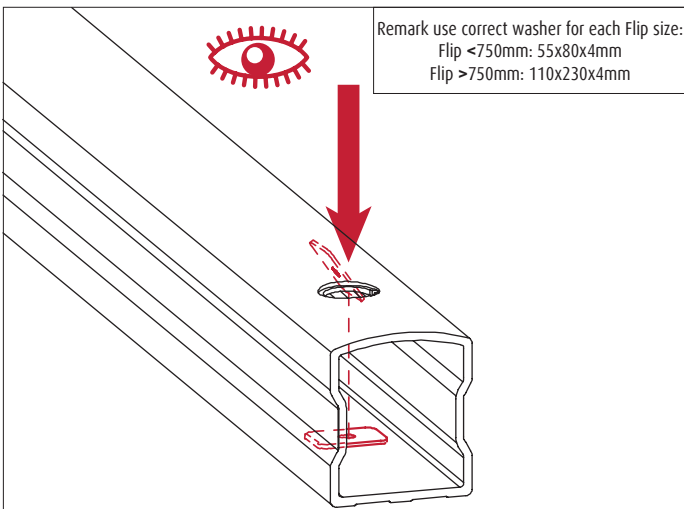

**9** Place a washer trough each hole and position correctly

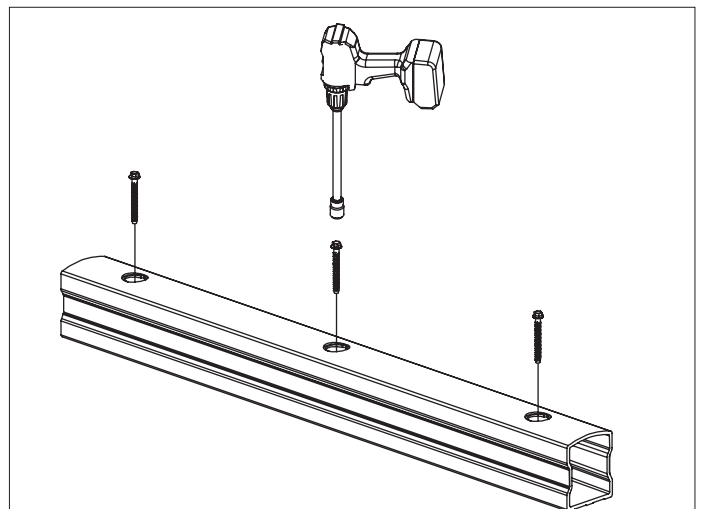

**10** Position the screws and tighten with impact wrench  
Torque = 100 Nm

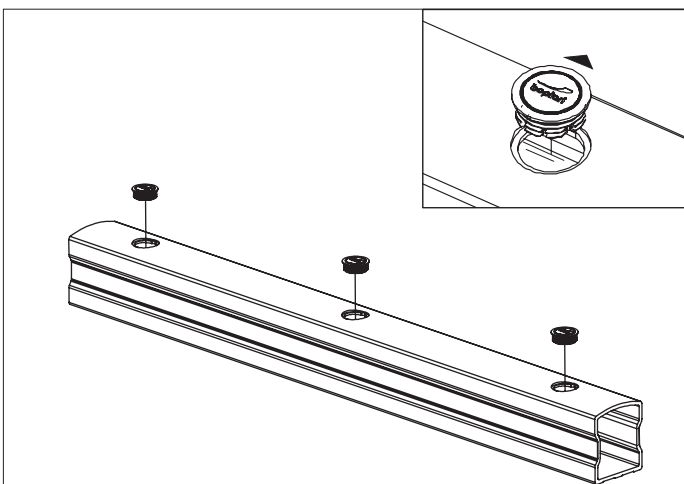

**11** Mount flex caps

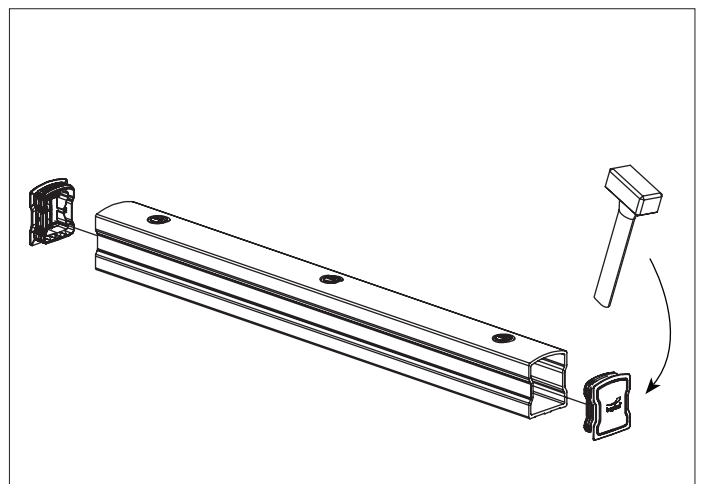

**12** Mount end caps