

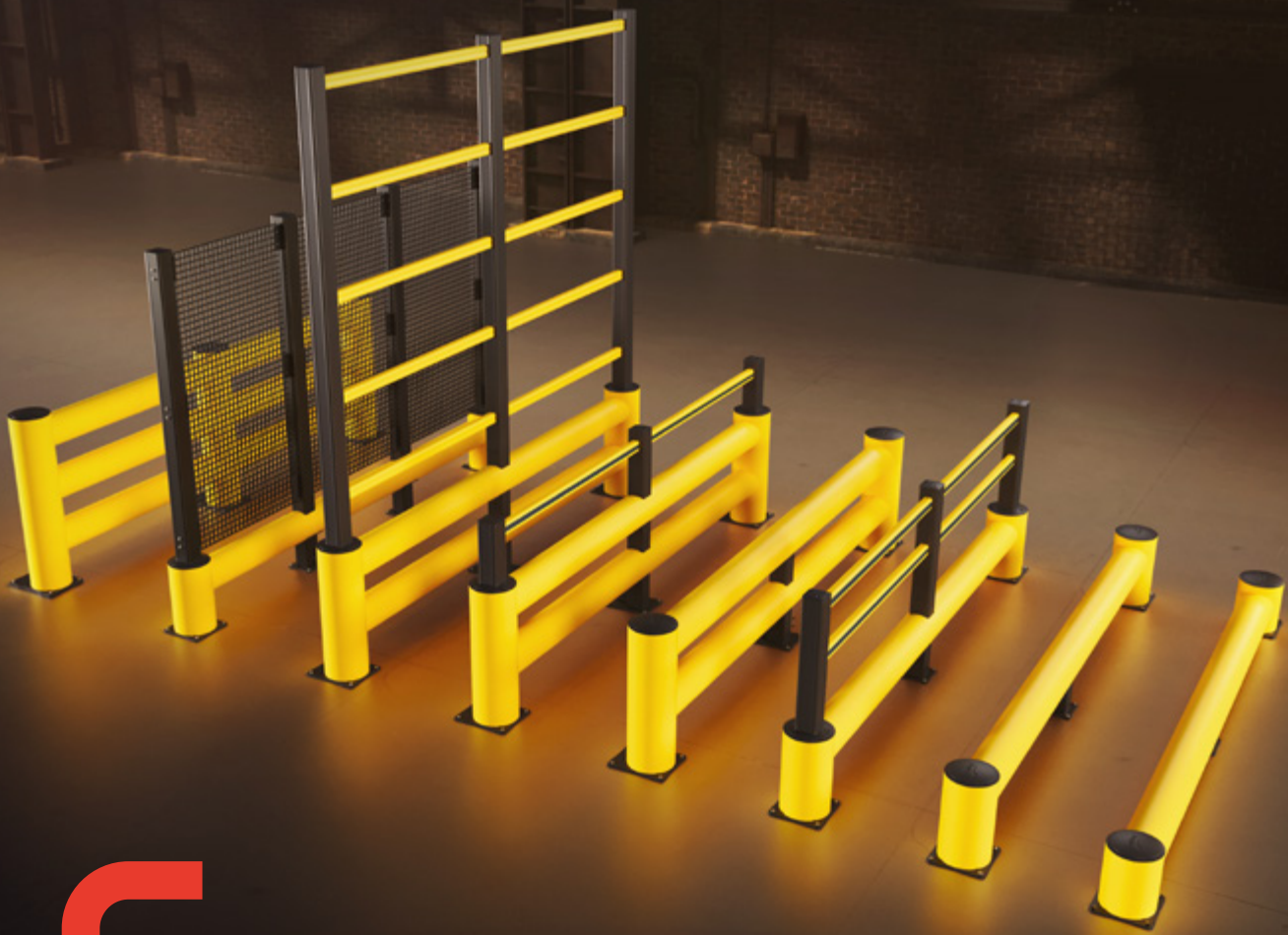

**READY  
FOR  
IMPACT**



# **SAFETY BARRIERS**

**PROTECTION OF PEOPLE, MACHINES,  
EQUIPMENT, INFRASTRUCTURE AND  
BUILDINGS AGAINST VEHICLES**



# SAFETY BARRIERS



**PROTECTION OF PEOPLE, MACHINES,  
EQUIPMENT, INFRASTRUCTURE  
AND BUILDINGS AGAINST VEHICLES**

FLEX IMPACT® safety barriers provide protection against collisions with forklifts and other vehicles. They are indispensable in busy traffic environments or locations where loads are moved or transported, such as warehouses, production halls and airports.

A unique characteristic of this safety solution is that a collision will not rip the fasteners out of the ground, and the flexible components retain their original shape after the impact. Thanks to the safety barriers' modular design, you can install your company's safety equipment zone by zone or expand it later.



**ICE FLEX®**

For temperatures down to **-30°C**



**EFFECTIVE SAFETY BARRIERS  
PREVENT SERIOUS AND EVEN FATAL ACCIDENTS.**

Effective safety barriers prevent severe and even fatal accidents. It is therefore crucial to make a well-considered choice based on the right criteria.

Boplan offers a wide range of safety barrier systems for mobile equipment. These are perfect for high-risk zones with mixed pedestrian and forklift traffic. They also provide ground-level protection and protect pedestrians from poorly stacked or falling objects.

Safety barriers are a solution primarily designed to protect pedestrians, infrastructure and buildings from collisions and damage caused by vehicles. They are the perfect solution to keep designated routes clear by separating pedestrian traffic from vehicles. We offer various types of safety barriers that can also be combined with our other safety products.

## FLEX IMPACT® SAFETY BARRIERS

### KEY FEATURES AND BENEFITS



#### IMPACT RESISTANCE AND FLEXIBILITY

Our products are made from EXTRILENE®, a high-performance polymer. This material is ideal for absorbing heavy impacts. Crash tests show that our safety barriers can withstand impacts of up to 50.10 kJ, depending on the model. The deformation that occurs after each collision disappears once the vehicle has gone.



#### EASY INSTALLATION DUE TO MODULAR DESIGN

Our safety barriers are constructed using a minimum of components. You don't need screws or bolts to secure these components. All parts slide or click together. This allows a certain degree of freedom of movement. And that's a very good thing, because a rigid lock increases the risk of breakage on impact. Moreover, the polymer components are lightweight, making them easy to handle and transport.

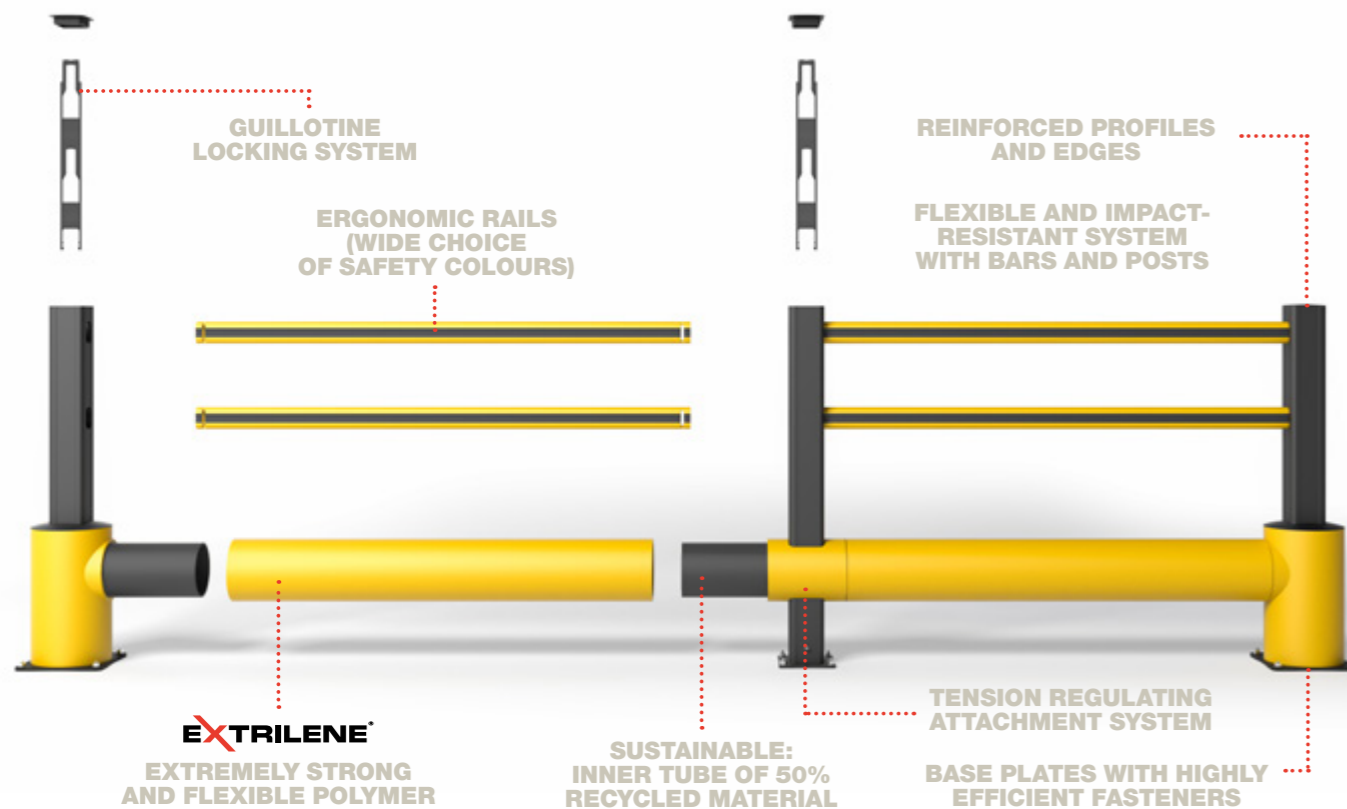

### TYPICAL ENVIRONMENTS

For the protection of people, machines, equipment, infrastructure and buildings in:

- Warehouses and storage facilities
- Distribution centres
- Transport & logistics centres
- Food industry
- Parking facilities
- Logistics, supply chain and material handling industries
- Petrochemical and chemical industries
- Aviation

### ICE FLEX®

Protection in environments down to -30°C.

ICE FLEX® safety barriers offer optimal impact protection and maximum safety in extremely cold conditions.

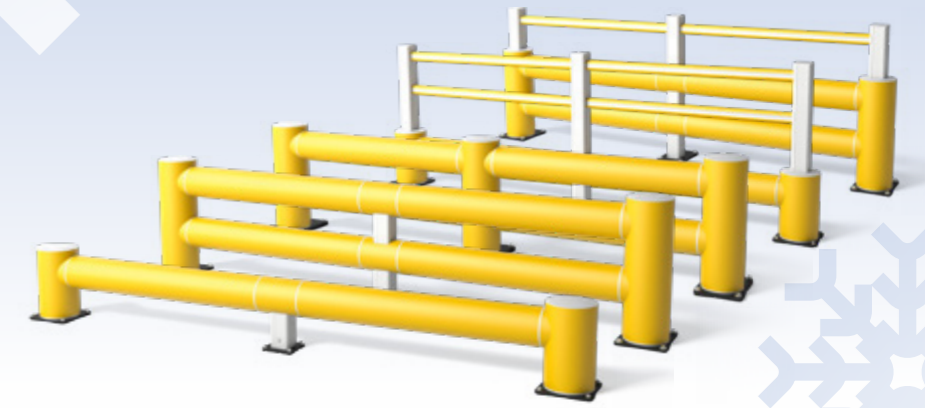

#### EASY TO CUSTOMISE AND EXPAND

Our safety barriers are available in different sizes and configurations. They are also easy to expand. This makes them suitable for rapidly changing environments. You can easily adapt them to your needs, unlike steel safety barriers, which must be welded. Additionally, you can easily connect the safety barriers to other FLEX IMPACT® safety products such as safety gates, handrails and bollards.



#### OPTIMAL VISIBILITY

The safety barriers' standard colour is yellow, as yellow grabs attention and increases safety awareness. The safety barriers are also available in other colours such as red. Red is commonly used for matters related to fire safety. Thanks to this recognisability, the colour reinforces the function. This allows for a fast and efficient response in precarious situations. Moreover, the polymer is coloured throughout, eliminating the need for painting.



Read the full case online

Red TB 260 PLUS set-up to protect a fire hose reel in a JCL Logistics warehouse (the Netherlands).



#### RESISTANCE TO CHEMICALS AND UV RADIATION

Our weather-resistant safety barriers are resistant to chemicals and do not rust. They are perfect for environments where the use of chemicals is common and strict hygiene standards apply. Bacteria do not adhere to the polymer and it is easy to clean.



#### LOW MAINTENANCE

FLEX IMPACT® safety barriers require little to no maintenance. When used correctly, our systems have an extremely long lifespan.

# SAFETY BARRIERS



FLEX IMPACT® TB safety barriers protect people, machines, equipment, infrastructure and buildings from forklifts and other vehicles. Our range includes models that act as wheel guides or wheel stops, as well as models that can stop heavy forklifts. The impact resistance ranges from 5 kJ to an impressive 50.1 kJ. The gap between the ground and the bottom of the bar also varies depending on the model. The key is to choose the right set-up for your needs. You can rely on our team of experts to help you make the right choice.

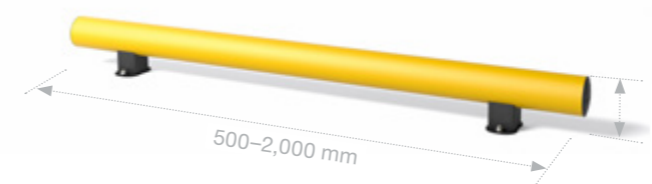

**TB MINI**  
5.00 kJ

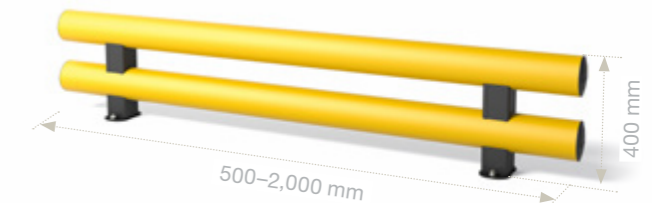

**TB MINI DOUBLE**  
5.00 kJ

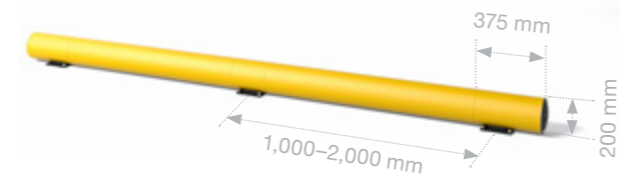

**TB 200**  
21.80 kJ

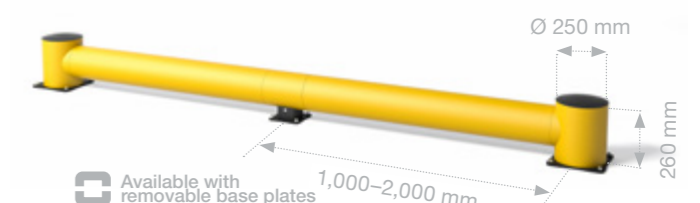

**TB 260**  
21.20 kJ

Available with removable base plates

# TB MINI

## BOPLAN IMPACT CALCULATOR

With the Boplan Impact Calculator, you can accurately calculate the required impact resistance for your safety barriers. This powerful tool is easy to use and allows you to make informed decisions with just a few clicks.

Enter specific parameters related to your workspace to instantly receive recommendations on the most suitable models and strength levels of safety barriers to avoid accidents and protect valuable assets.

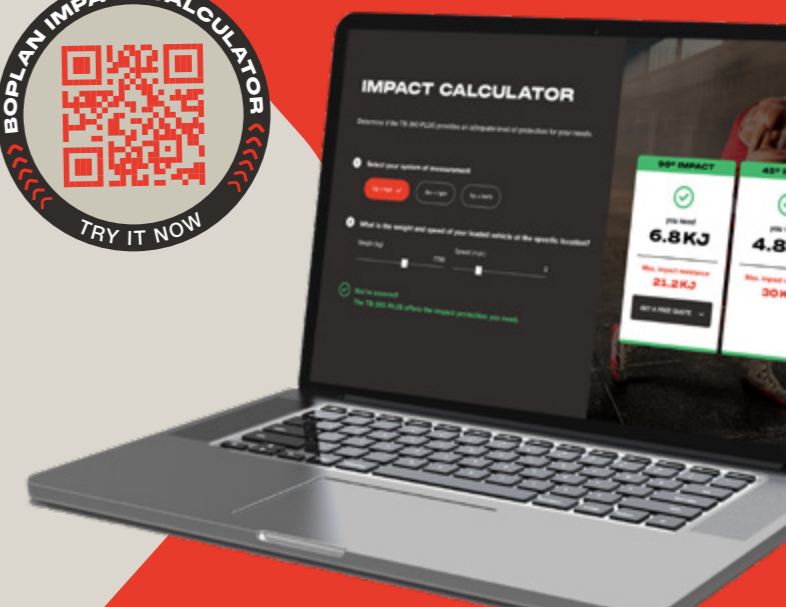

**FLEX IMPACT® SAFETY BARRIERS**



**TB 260 DOUBLE**  
**46.50 kJ**



Available with removable base plates

**TB 400**  
**20.10 kJ**



**TB 400 DOUBLE**  
**39.10 kJ**

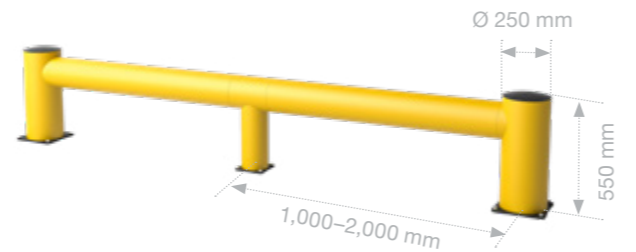

**TB 550**  
**18.30 kJ**

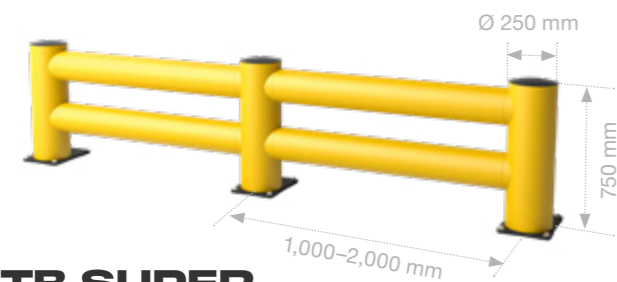

**TB SUPER DOUBLE**  
**50.10 kJ**

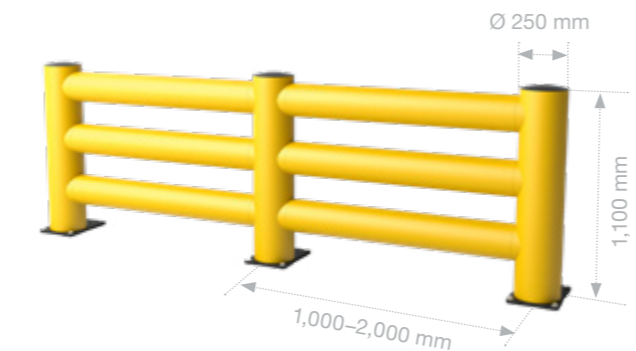

**TB SUPER TRIPLE**  
**48.30 kJ**



**TB 400 DOUBLE**



FLEX IMPACT® SAFETY BARRIERS

# SAFETY BARRIERS WITH RAIL SYSTEM



FLEX IMPACT® TB PLUS safety barriers consist of a strong barrier plus one or two handrails. This safety solution protects pedestrians from collisions with forklifts and other vehicles. It creates an effective separation between the pedestrian walkway and the area where the forklifts are active.

## TB 260 PLUS

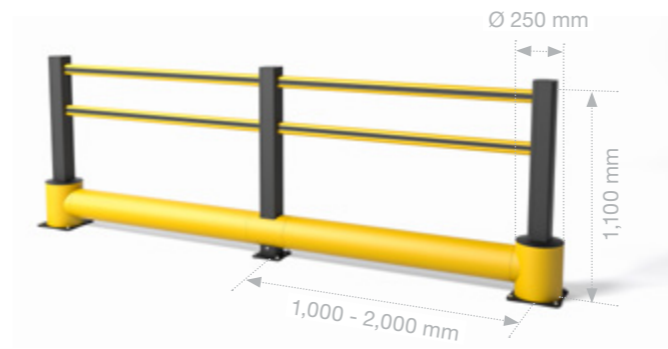

**TB 260 PLUS**  
21.20 kJ

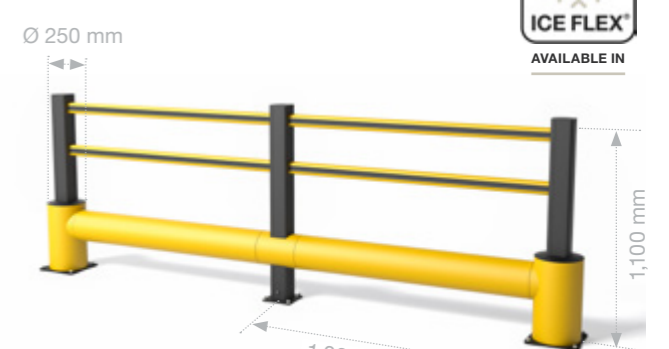

**TB 400 PLUS**  
20.10 kJ

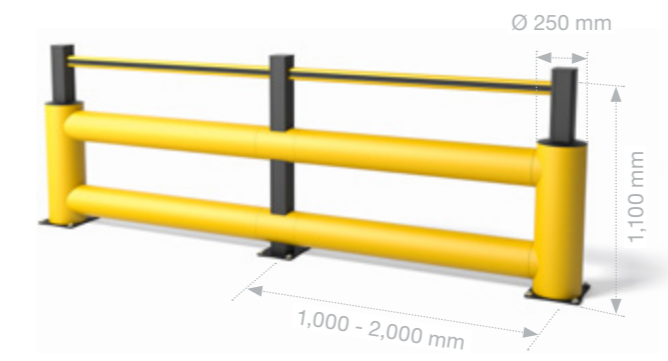

**TB 260 DOUBLE PLUS**  
46.50 kJ



**TB 400 DOUBLE PLUS**  
39.10 kJ



# SAFETY BARRIER AGAINST FALLING GOODS



The FLEX IMPACT® TB GRILL safety barrier combines a strong barrier with a series of bars. This type of safety barrier protects pedestrians from falling goods and collisions with forklifts and other vehicles. It provides pedestrians with enhanced safety in storage areas with forklift traffic. Depending on the size of the goods, you can opt for a set-up with either 275 mm or 550 mm of space between the bars.

**TB 260 GRILL**  
21.20 kJ

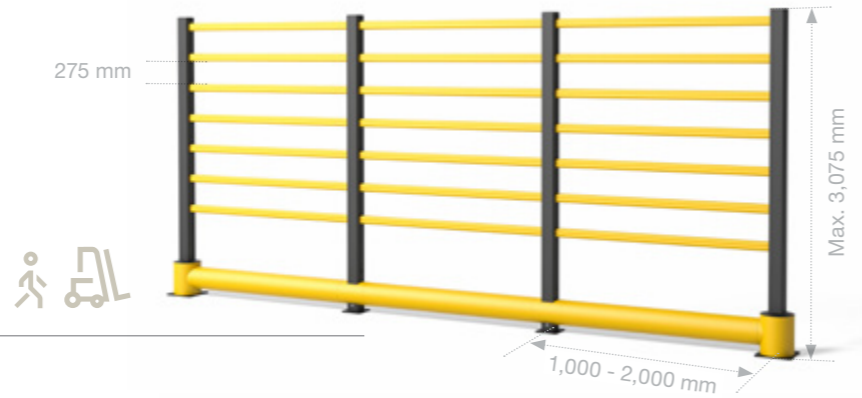

**TB 400 GRILL**  
20.10 kJ

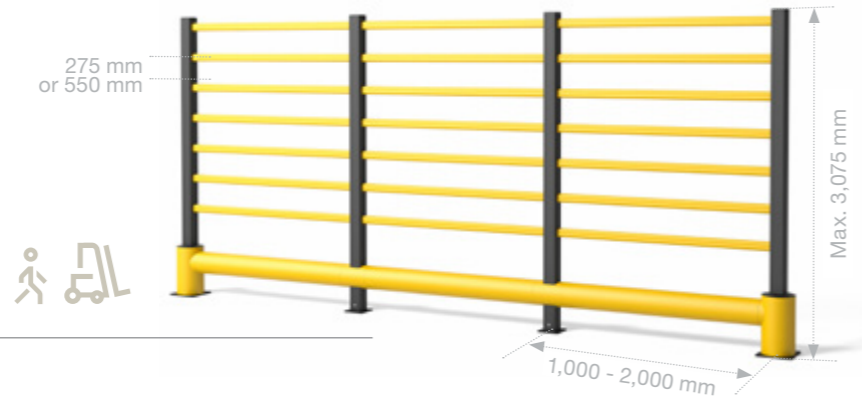

**TB 400  
DOUBLE GRILL**  
39.10 kJ

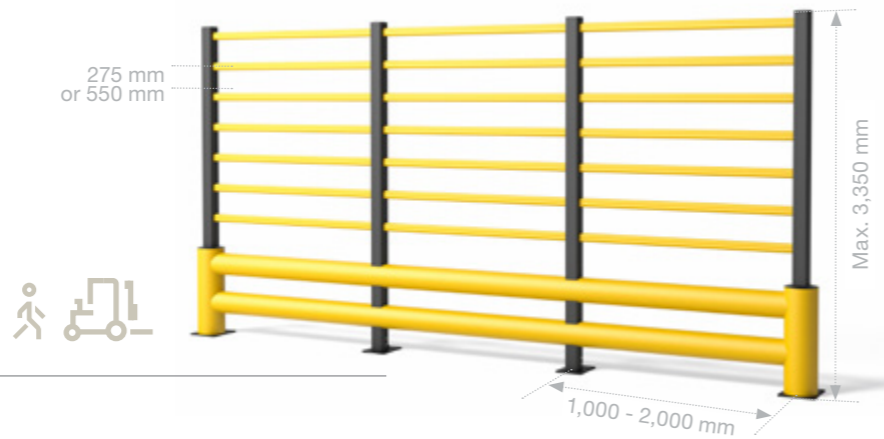

**TB 260 GRILL**



FLEX IMPACT® SAFETY BARRIERS

# SAFETY BARRIERS WITH FENCING



FLEX IMPACT® TB PLUS FENCE safety barriers combine a strong barrier and built-in fencing. With this fencing, the TB 260 and TB 400 reach a height of 2,300 mm. This provides protection for machinery from falling goods and keeps pedestrians at a safe distance. The TB 550, with its height of 1,100 mm, is designed for the protection of pedestrians in parking garages, parking lots and ramps. These strong and flexible safety barriers absorb impact, and the integrated fencing offers additional pedestrian protection.



Available with removable base plates

**TB 260 PLUS FENCE**  
21.20 kJ



Available with removable base plates

**TB 400 PLUS FENCE**  
20.10 kJ

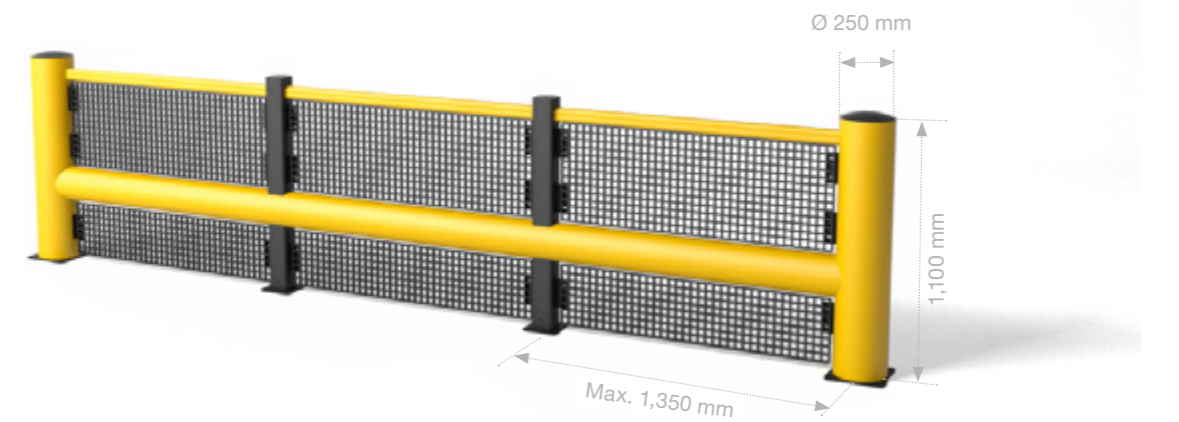

**TB 550 PLUS FENCE**  
18.30 kJ

# TB 260 PLUS FENCE



**READY  
FOR  
IMPACT**

### **BOPLAN HQ**

Muizelstraat 12  
8560 Moorsele, Belgium  
+32 56 20 64 20  
info@boplan.com

### **BOPLAN UK**

Science Centre, Wolverhampton Science Park  
Glaisher Drive, Wolverhampton WV10 9RU  
+44 1902 82 4280  
info@boplan.co.uk

### **BOPLAN USA**

4350 W. White Road, St 300  
Flowery Branch, GA 30542  
+1 678-890-5906  
info@boplan.us

### **BOPLAN DEUTSCHLAND**

IHP-Nord · Babenhäuser Str. 50  
63762 Großostheim  
+49 6026 999 51 90  
info@boplan.de

### **BOPLAN FRANCE**

617, Avenue de Bayonne  
64210 Bidart  
+33 (0)5 35 45 75 35  
info@boplan.fr

### **BOPLAN ESPAÑA**

Carrer d'Aragó 208, 2o 6a  
08002 Barcelona  
+34 936 81 66 88  
info@boplan.es

### **BOPLAN NEDERLAND**

Toermalijnring 100  
3316 LC Dordrecht  
+31 85 13 07 500  
info@boplan.nl

### **BOPLAN POLSKA**

Ul. Graniczna 34B / U16  
41-300 Dąbrowa Górnicza  
+48 32 224 74 85  
info@boplan.pl

### **BOPLAN ITALIA**

Via Privata Maria Teresa 7  
20123 Milano  
+39 02 81287168  
info@boplan.it

### **BOPLAN JAPAN**

4F Matsuoka II Building,  
1-2-11 Nijyooji Minami  
Nara City, Nara 630-8012  
+81 (0)742-93-8705  
info@boplan.co.jp

### **FOLLOW US**



### **BOPLAN.COM**

For more information about our products,  
services and worldwide network

