



**READY  
FOR  
IMPACT**



# **SAFETY BARRIERS**

**PROTECTION OF PEOPLE, MACHINES,  
EQUIPMENT, INFRASTRUCTURE, AND  
BUILDINGS AGAINST VEHICLES**

# SAFETY BARRIERS



PROTECTION OF PEOPLE, MACHINES,  
EQUIPMENT, INFRASTRUCTURE,  
AND BUILDINGS AGAINST VEHICLES

FLEX IMPACT® safety barriers provide protection against collisions with forklifts and other vehicles. These are essential in busy traffic environments or locations where loads are moved or transported, such as warehouses, production facilities, and airports.

A unique feature of this safety solution is that a collision will not pull the fasteners out of the ground, and the flexible components retain their original shape after impact. Thanks to the modular design of the safety barriers, you can install your company's safety equipment zone by zone or expand it later.



ICE FLEX®

For temperatures down to -22°F



Effective safety barriers prevent severe and even fatal accidents. Therefore, it's crucial to make a well-considered choice based on the right criteria.

Boplan provides a wide range of safety barrier systems for mobile equipment. These are ideal for high-risk zones with mixed pedestrian and forklift traffic. They also offer ground-level protection and protect pedestrians from poorly stacked or falling objects.

**EFFECTIVE SAFETY BARRIERS  
PREVENT SERIOUS AND EVEN FATAL ACCIDENTS.**

Safety barriers are primarily designed to protect pedestrians, infrastructure, and buildings from collisions and damage caused by vehicles. They are the ideal solution to keep designated routes clear by separating pedestrian traffic from vehicles. We offer various types of safety barriers that can also be combined with our other safety products.

KEY FEATURES AND BENEFITS



IMPACT RESISTANCE AND FLEXIBILITY

Our products are made from Extrilene, a high-performance polymer. This material is ideal for absorbing heavy impacts. Crash tests show that our safety barriers can withstand impacts of up to 50.10 kJ, depending on the model. The deformation that occurs after each collision disappears once the vehicle has passed.



EASY INSTALLATION THANKS TO MODULAR DESIGN

Our safety barriers are constructed with a minimal number of components. You don't need screws or bolts to secure these components. All parts slide or click together. This allows for a certain degree of movement. And that's a very good thing because a rigid lock increases the risk of breakage on impact. Additionally, the polymer components are lightweight, making them easy to handle and transport.

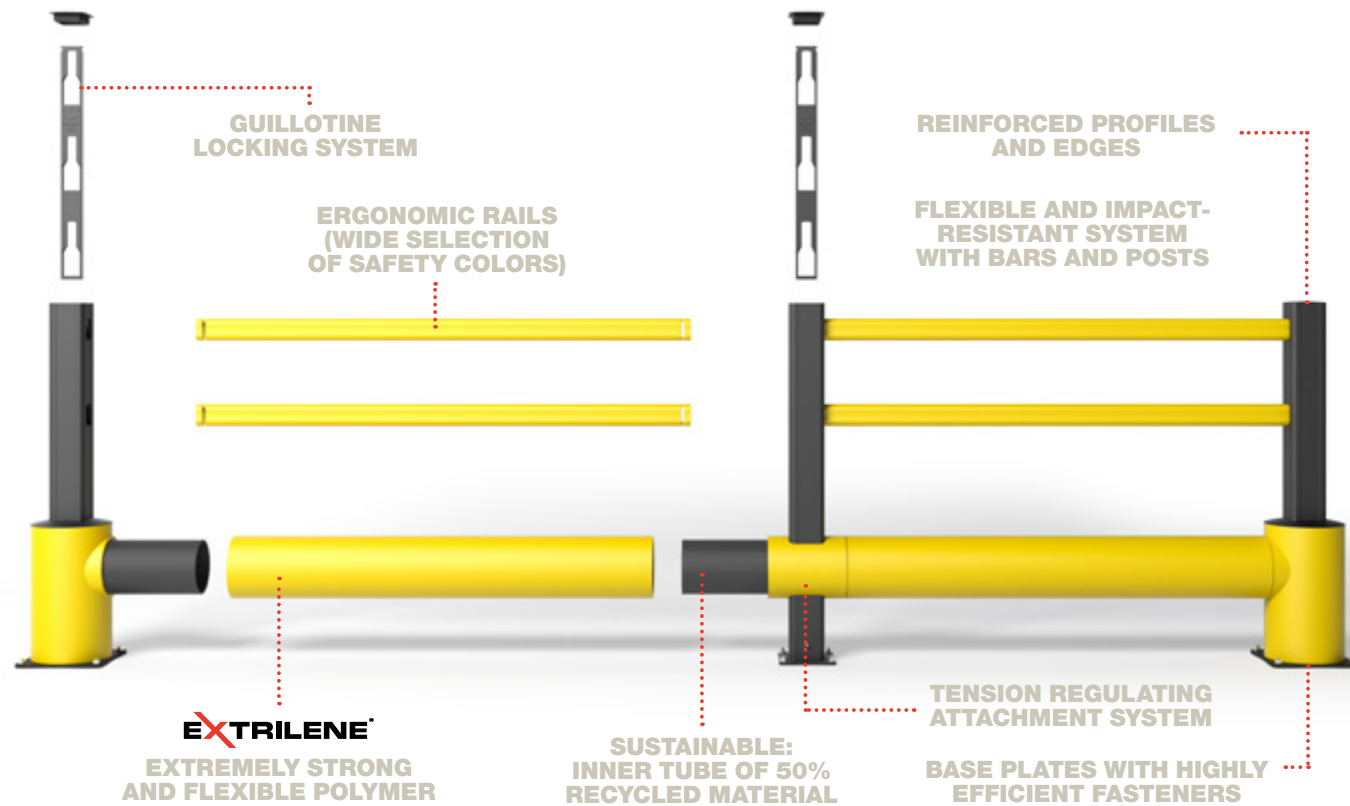

Protection in environments down to -22°F.

ICE FLEX® safety barriers offer optimal impact protection and maximum safety in extremely cold conditions.

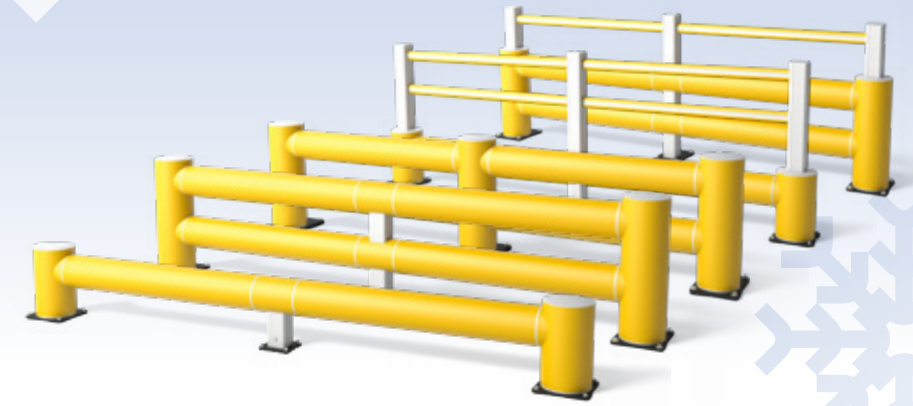

EASY TO CUSTOMIZE AND EXPAND

Our safety barriers come in various sizes and configurations. They are also easy to expand. This makes them ideal for rapidly changing environments. You can easily adapt them to your needs, unlike steel safety barriers, which require welding. Additionally, you can easily connect the safety barriers to other FLEX IMPACT® safety products such as safety gates, handrails and bollards.



OPTIMAL VISIBILITY

The standard color for the safety barriers is yellow, as yellow grabs attention and increases safety awareness. The safety barriers are also available in other colors such as red. Red is commonly used for matters related to fire safety. Thanks to this recognizability, the color reinforces the function. This enables a fast and efficient response in critical situations. Additionally, the polymer is colored throughout, eliminating the need for painting.

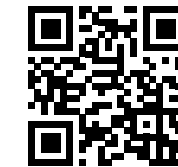

Read the full case online

Red TB 260 PLUS setup to protect a fire hose reel in a JCL Logistics warehouse (Netherlands).



RESISTANCE TO CHEMICALS AND UV RADIATION

Our weather-resistant safety barriers resist chemicals and do not rust. They are ideal for environments where chemicals are used frequently, and strict hygiene standards apply. Bacteria do not adhere to the polymer, and it's easy to clean.



LOW MAINTENANCE

FLEX IMPACT® safety barriers require little to no maintenance. When used correctly, our systems have an exceptionally long lifespan.

TYPICAL ENVIRONMENTS

For the protection of people, machines, equipment, infrastructure, and buildings in:

- Warehouses and storage facilities
- Distribution centers
- Transport & logistics centers
- Food industry
- Parking facilities
- Logistics, supply chain, and material handling industries
- Petrochemical and chemical industries
- Aviation





FLEX IMPACT® SAFETY BARRIERS

# SAFETY BARRIERS



FLEX IMPACT® TB safety barriers protect people, machines, equipment, infrastructure, and buildings from forklifts and other vehicles. Our range includes models that act as wheel guides or stops, as well as models that can stop heavy forklifts. The impact resistance ranges from 5 kJ to an impressive 50.1 kJ. The gap between the ground and the bottom of the bar also varies based on the model. The key is to choose the right setup for your needs. You can count on our team of experts to help you make the right choice.

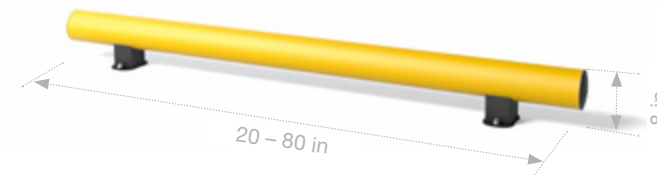

**TB MINI**  
5.00 kJ

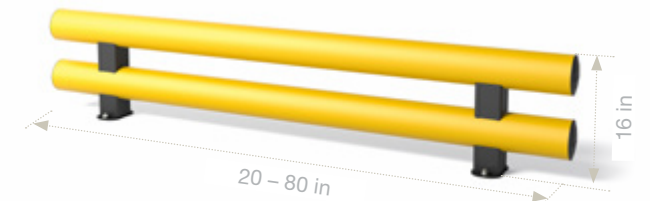

**TB MINI DOUBLE**  
5.00 kJ

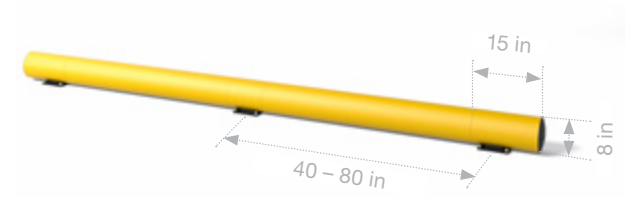

**TB 200**  
21.80 kJ

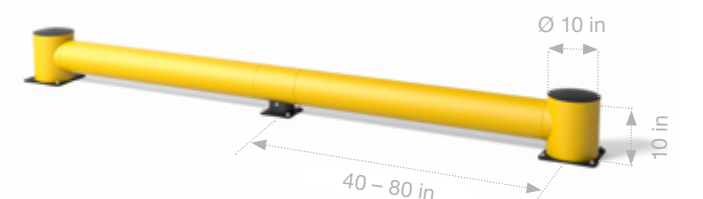

**TB 260**  
21.20 kJ



# TB MINI

## BOPLAN IMPACT CALCULATOR

With the Boplan Impact Calculator, you can accurately calculate the necessary impact resistance for your safety barriers. This powerful tool is easy to use and enables you to make informed decisions with just a few clicks.

Enter specific parameters related to your workspace to instantly receive recommendations on the best models and strength levels of safety barriers to prevent accidents and protect valuable assets.



FLEX IMPACT® SAFETY BARRIERS

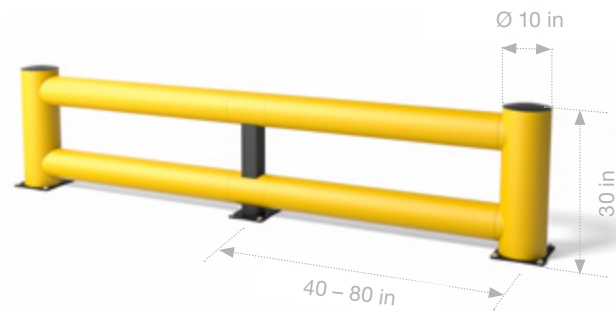

**TB 260 DOUBLE**  
46.50 kJ

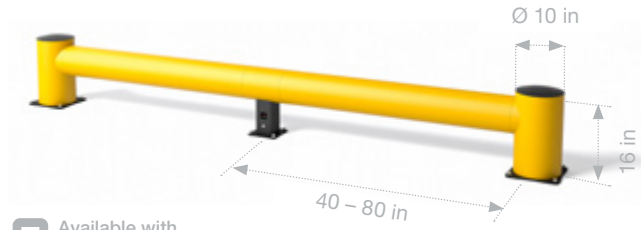

Available with removable base plates

**TB 400**  
20.10 kJ

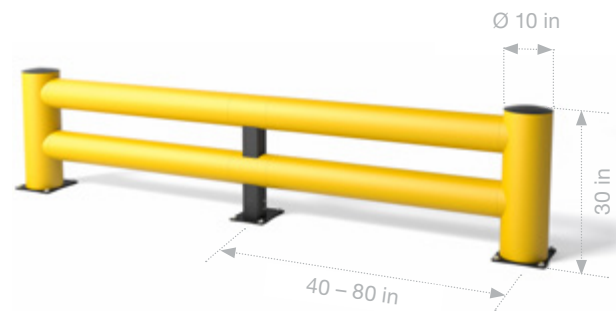

**TB 400 DOUBLE**  
39.10 kJ

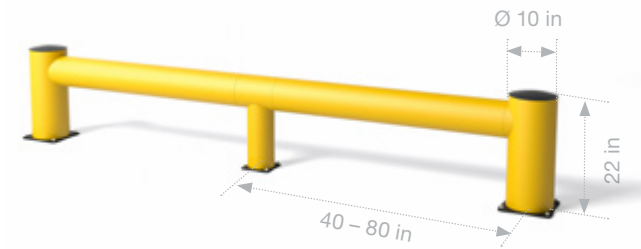

**TB 550**  
18.30 kJ

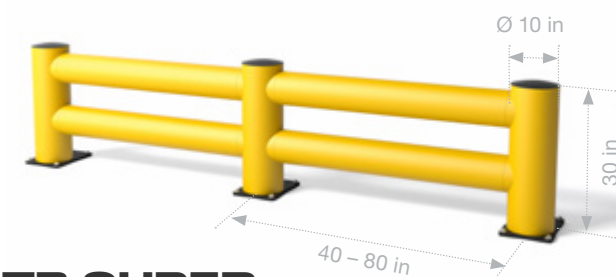

**TB SUPER DOUBLE**  
50.10 kJ

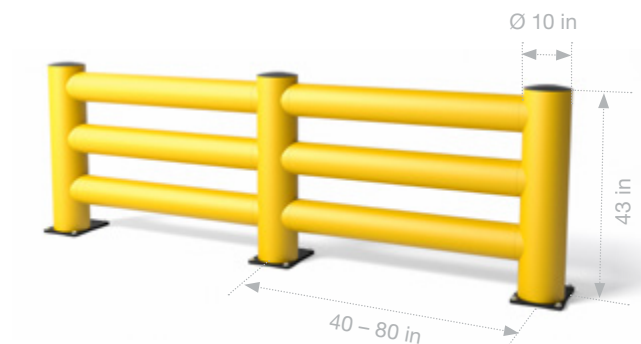

**TB SUPER TRIPLE**  
48.30 kJ



**TB 400 DOUBLE**



FLEX IMPACT® SAFETY BARRIERS

# SAFETY BARRIERS WITH RAIL SYSTEM



FLEX IMPACT® TB PLUS safety barriers consist of a strong barrier and one or two handrails. This safety solution protects pedestrians from collisions with forklifts and other vehicles. It creates a clear separation between the pedestrian walkway and the area where forklifts are active.

# TB 260 PLUS

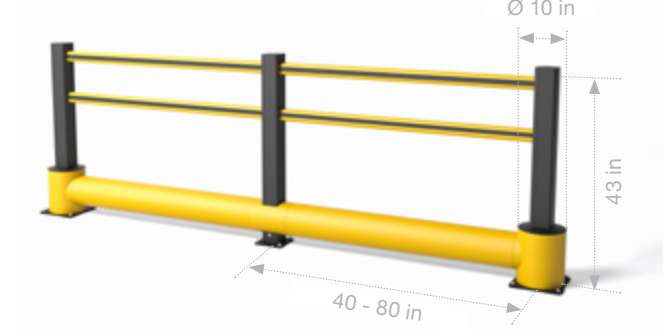

**TB 260 PLUS**  
21.20 kJ

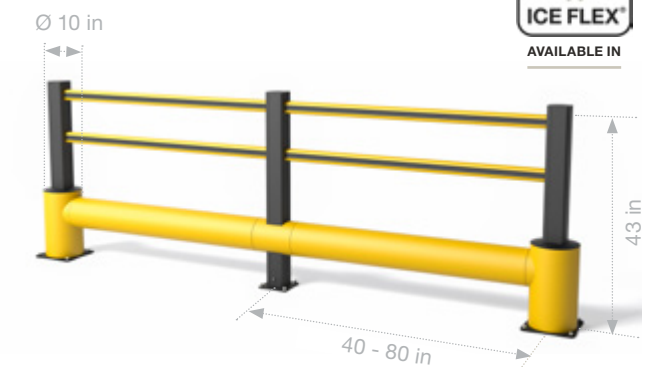

**TB 400 PLUS**  
20.10 kJ

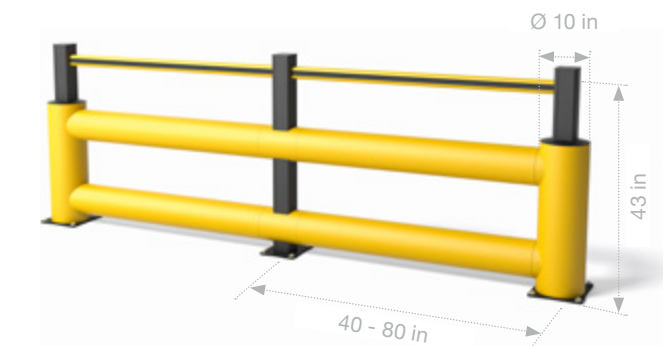

**TB 260 DOUBLE PLUS**  
46.50 kJ

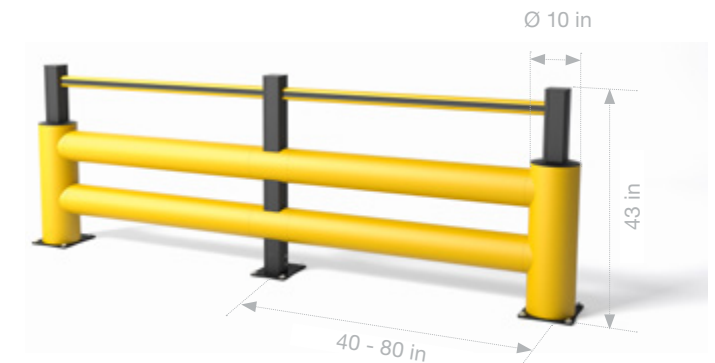

**TB 400 DOUBLE PLUS**  
39.10 kJ



# SAFETY BARRIER AGAINST FALLING GOODS



The FLEX IMPACT® TB GRILL safety barrier combines a strong barrier with a series of bars. This type of safety barrier protects pedestrians from falling goods and collisions with forklifts and other vehicles. It provides pedestrians with increased safety in storage areas with forklift traffic. Depending on the size of the goods, you can opt for a setup with either 11 inch or 22 inch of space between the bars.

**TB 260 GRILL**  
21.20 kJ

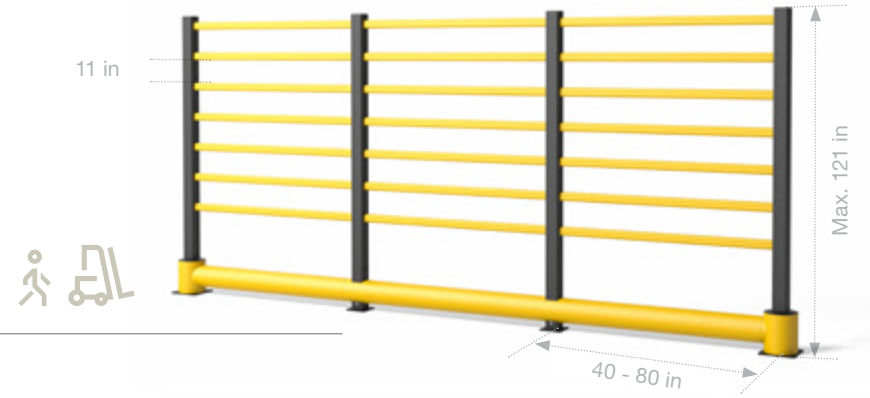

**TB 400 GRILL**  
20.10 kJ

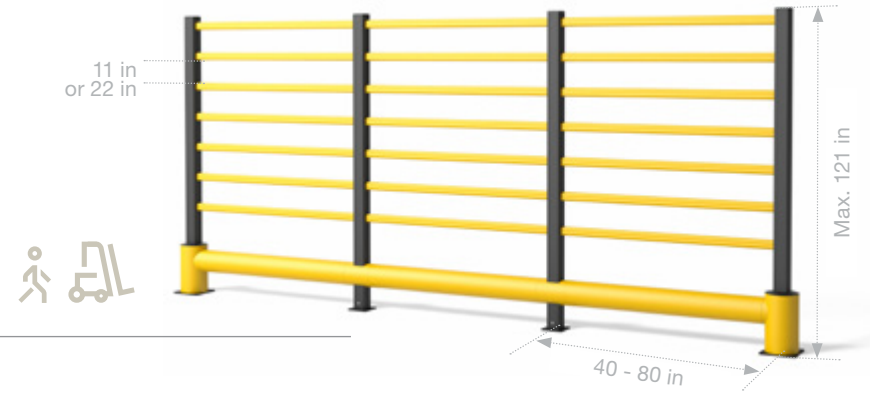

**TB 400 DOUBLE GRILL**  
39.10 kJ



**TB 260 GRILL**



# TB 260 PLUS FENCE

FLEX IMPACT® SAFETY BARRIERS

## SAFETY BARRIERS WITH FENCING



FLEX IMPACT® TB PLUS FENCE safety barriers combine a strong barrier with integrated fencing. With this added fencing, the TB 260 and TB 400 reach a height of 2,300 mm (90.6"), which helps to shield machinery from falling goods while keeping pedestrians at a safe distance. The TB 550, at 1,100 mm (43.3") high, protects pedestrians in parking areas and on ramps. Built to absorb impacts, these strong yet flexible barriers add an extra level of pedestrian safety. For long-lasting performance, the fencing is resistant to corrosion, chemicals, and environmental pollution. Because they are non-conductive, you can use these barriers safely around high-voltage equipment, even in demanding industrial environments.

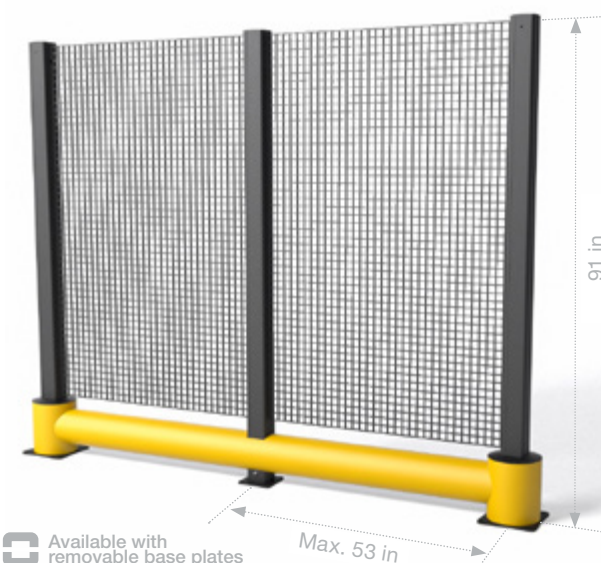

**TB 260 PLUS FENCE**  
21.20 kJ

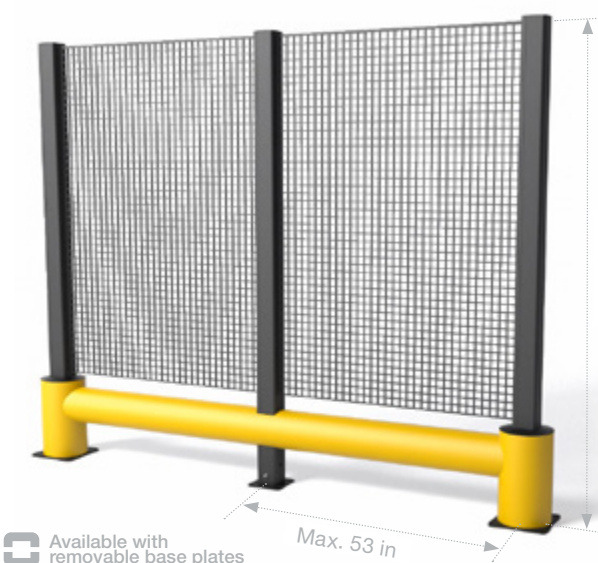

**TB 400 PLUS FENCE**  
20.10 kJ

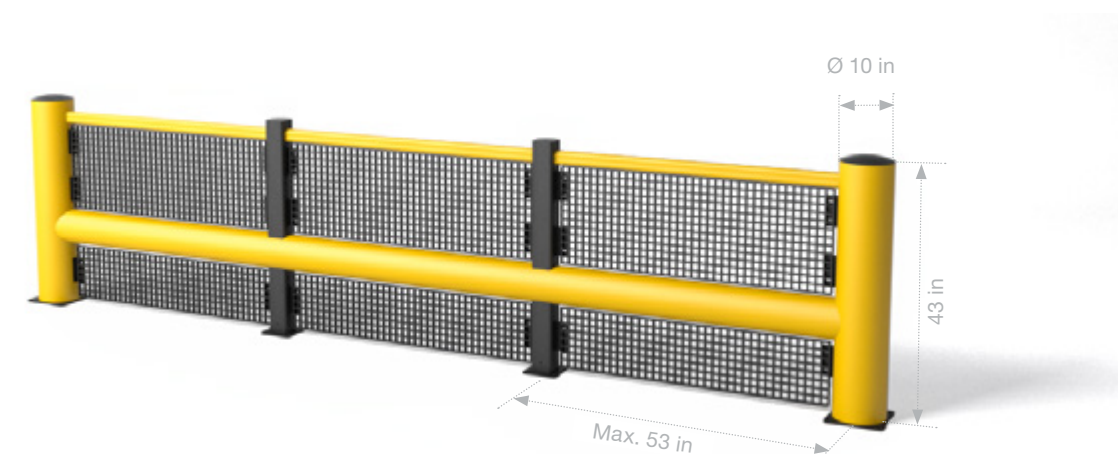

**TB 550 PLUS FENCE**  
18.30 kJ



### **BOPLAN HEADQUARTERS**

Muizelstraat 12  
8560 Moorsele, Belgium  
+32 56 20 64 20  
info@boplan.com

### **BOPLAN USA**

4350 W. White Road, St 300  
Flowery Branch, GA 30542  
+1 678-890-5906  
info@boplan.us

### **BOPLAN UK**

Science Centre, Wolverhampton Science Park  
Glaisher Drive, Wolverhampton WV10 9RU  
+44 1902 82 4280  
info@boplan.co.uk

### **BOPLAN DEUTSCHLAND**

IHP-Nord · Babenhäuser Str. 50  
63762 Großostheim  
+49 6026 999 51 90  
info@boplan.de

### **BOPLAN FRANCE**

617, Avenue de Bayonne  
64210 Bidart  
+33 (0)5 35 45 75 35  
info@boplan.fr

### **BOPLAN ESPAÑA**

Carrer d'Aragó 208, 2o 6a  
08002 Barcelona  
+34 936 81 66 88  
info@boplan.es

### **BOPLAN NEDERLAND**

Toermalijnring 100  
3316 LC Dordrecht  
+31 85 13 07 500  
info@boplan.nl

### **BOPLAN POLSKA**

Ul. Graniczna 34B / U16  
41-300 Dąbrowa Górnicza  
+48 32 224 74 85  
info@boplan.pl

### **BOPLAN ITALIA**

Via Privata Maria Teresa 7  
20123 Milano  
+39 02 81287168  
info@boplan.it

### **BOPLAN JAPAN**

4F Matsuoka II Building,  
1-2-11 Nijyooji Minami  
Nara City, Nara 630-8012  
+81 (0)742-93-8705  
info@boplan.co.jp

### **FOLLOW US**



**BOPLAN.COM**

For more information about our products,  
services, and worldwide network

