

# CORNER PROTECTOR

## COLUMN AND CORNER PROTECTION

Revision: 24 March 2025 3:33 PM  
Boplan reference: CP0100-1000-S101..

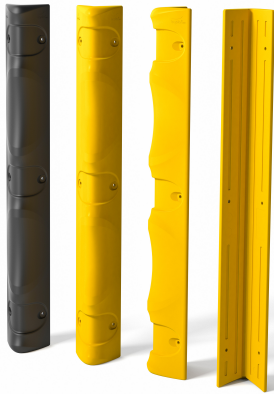

### PRODUCT SPECIFICATIONS

APPLICATION	
Environment	Heavy duty corner protector. Protection of pillars and corners in department stores, car parks, warehouses, ... against manoeuvring pallet trucks and other vehicles. Not intended for vehicle impact
MATERIAL	
Corner protector	Rexilene® - UV resistant - Fire class E <sup>®</sup> - Non conductive - Impervious to most chemicals**
STANDARD COLOURS	
Column protector	Standard: Yellow RAL 1003 Also available in Black RAL 9005 (multicolour)
FIXATIONS	
Concrete screw ZC (included)	Length = 45 mm Size = Ø 7.5 mm Drill hole diameter = 6 mm Max load (pull out) = 2.0 kN Screw drive = Torx 30 (T30)
Velcro straps (not included)	Use multiple Corner Protectors around a pillar with velcro straps.
REQUIREMENTS	
Angle of corner	Between 85° and 100°
Environment	Indoor and outdoor use
Working Temperatures	-30°C up to +40°C

\*Classification according to EN 13501-1:2007 +A1:2009 - Fire classification of construction products and building elements.  
\*\*Ask your local sales office for resistance to specific chemicals.

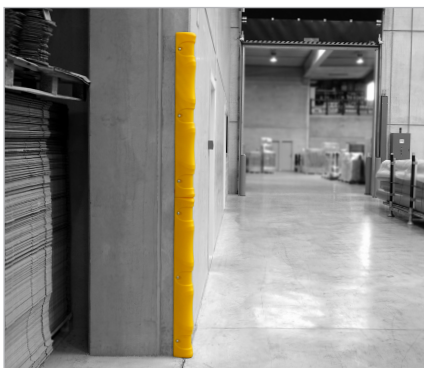



**FEATURES AND FUNCTIONALITY - CORNER PROTECTOR**

SIZE	
Outer diameter	140 mm x 140 mm
Inner dimension	100 mm x 100 mm
Weight	1.8 kg

IMPACT PERFORMANCE		
Test conditions	Ambient temperature Fork lift weight Success criteria	20°C 2300kg No permanent damage
90° impact	Maximum impact	500 Joule
45° impact	Maximum impact	500 Joule

**REFERENCES PRODUCT - CORNER PROTECTOR**

CP0100-1000-S101YE	CP0100-1000-S101BL
YELLOW	BLACK
	

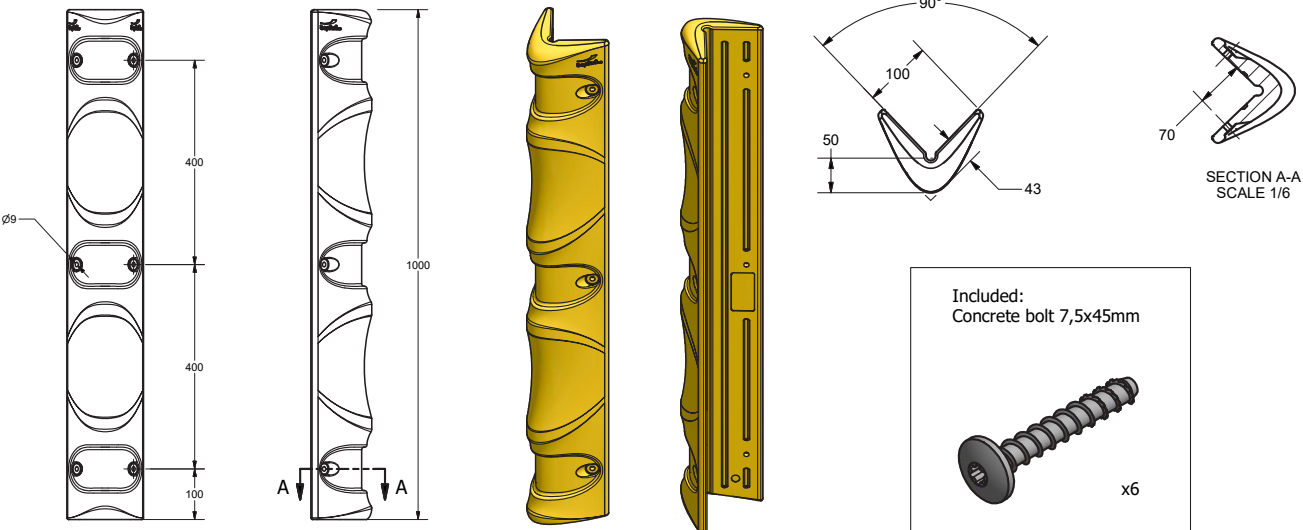

Technical drawings showing front, side, and perspective views of the corner protector. Dimensions include a total height of 1000 mm, individual section heights of 400 mm, and a width of 100 mm. A 90-degree impact diagram shows a 100 mm radius and a 50 mm height. Section A-A is shown at a scale of 1/6 with a 70 mm dimension.

Included:  
Concrete bolt 7,5x45mm



x6