

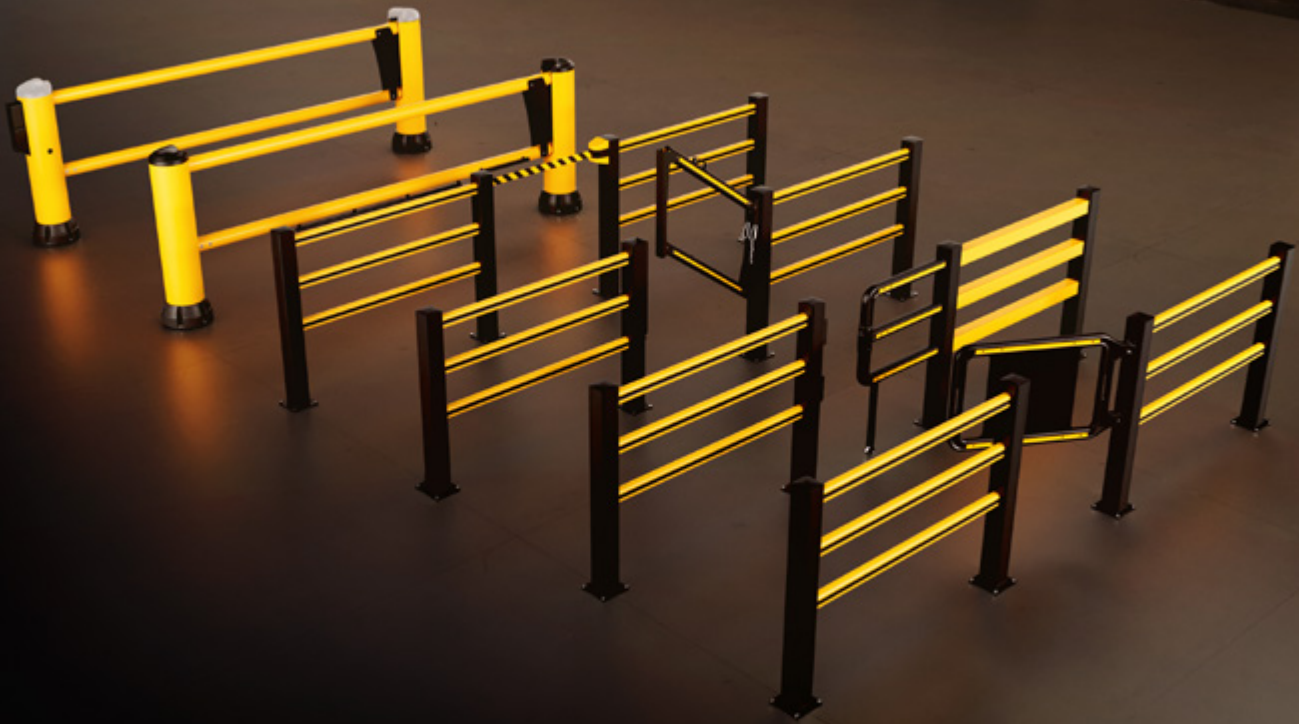

**READY
FOR
IMPACT**



SAFETY GATES

**RESTRICTING ACCESS
TO HAZARDOUS AREAS**



SG SWING GATE



SWING GATE

The FLEX IMPACT® **SG SWING GATE** is a bidirectional safety gate. Gates and entrances to corridors and machine rooms are often left open. The SG SWING GATE puts an end to this issue. This safety gate closes automatically, keeping access restricted at all times. The sturdy door is ergonomically designed and includes a sign.

LARGE SIGN BOARD

Warns employees and visitors about hazards

GATE STOP

Prevents the gate from swinging in a certain direction

LOCK BLOCK

Prevents the gate from remaining locked open

WHEEL SUPPORT

Standard for gates over 59 in wide



Combination of a **SWING GATE** with a **TB 400 PLUS** at the Instantprint warehouse (United Kingdom).

Read the full case online

KEY FEATURES AND FUNCTIONS

- Sturdy, impact-resistant safety gate with swinging open action
- Close off aisles in areas with inbound and outbound goods
- Clear marking of pedestrian area boundaries: warning function
- Saline and corrosive environments (food industry, coastal areas, etc.)
- Restrict access routes to machine rooms
- Suitable for outdoor use (optional SS 304 stainless steel components)
- Durable and built for heavy use
- Ergonomic design
- Compatible with safety barriers, handrails, and bollards
- Large sign board
- Lock block and stop
- Wheel support for gates over 59 in wide



4 POSSIBLE COMBINATIONS

The **SG SWING GATE** pairs seamlessly with FLEX IMPACT® safety barriers and handrails. Together, these safety elements ensure smooth and safe movement between different areas in your work environment.

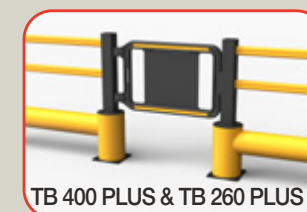

SG SLIDING GATE



SAFETY GATE THAT OPENS AND CLOSES BY SLIDING

The FLEX IMPACT® **SG SLIDING GATE** is a sliding safety gate. The gate can slide either to the left or right. When the gate opens, it rolls along the floor on a sturdy wheel, with its rails sliding into the adjoining guardrail profiles. This safety gate is easy to install.

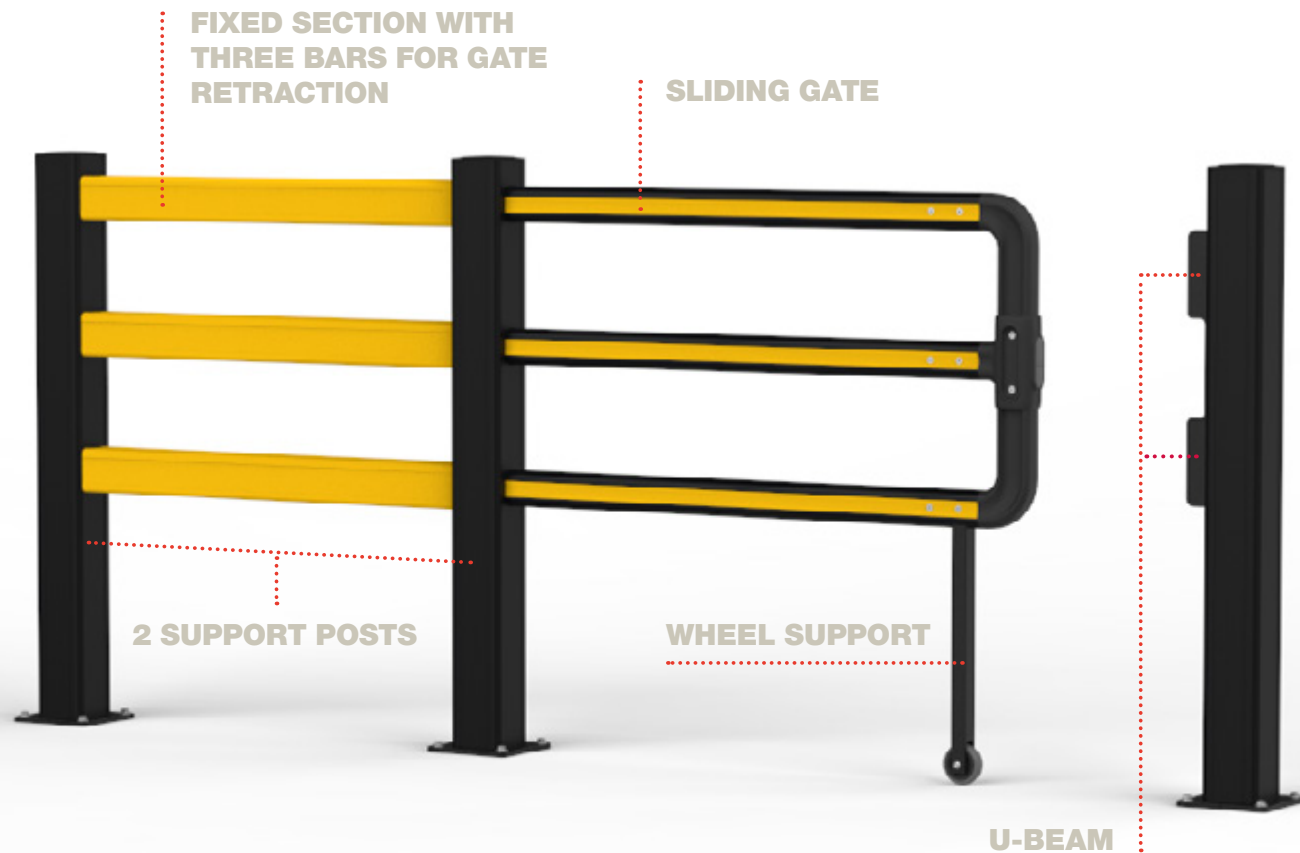

KEY FEATURES AND FUNCTIONS

- Sliding safety gate
- Restrict access routes to machine rooms
- Close off aisles in areas with inbound and outbound goods
- Durable and built for heavy use
- Close off aisles in areas with incoming and outgoing goods
- Ergonomic design
- Saline and corrosive environments (food industry, coastal areas, etc.)
- Compatible with safety barriers and handrails

COMPATIBLE WITH SAFETY BARRIERS AND HANDRAILS

The SLIDING GATE is part of the impact-resistant and stylish FLEX IMPACT® series. A sliding safety gate is ideal for spaces with limited room to maneuver. The SLIDING GATE also pairs well with our safety barriers and handrails. Together, these safety products ensure people's safe circulation.



SG DROP GATE



SAFETY DROP GATE THAT OPENS UPWARD

The FLEX IMPACT® **SG DROP GATE** is a safety gate that restricts access when there isn't enough room for a traditional swing gate. This gate opens upward. Like other safety gates in this series, the SG DROP GATE is a practical solution to block off walkways and areas.

CONVENIENT HANDLE

SUPPORT

STURDY HINGE



KEY FEATURES AND FUNCTIONS

- Safety drop gate that opens upward
- Close off aisles where a swing gate won't fit
- Saline and corrosive environments (food industry, coastal areas, etc.)
- Restrict access routes to machine rooms
- Durable and built for heavy use
- Ergonomic design
- Compatible with safety barriers and handrails
- For openings up to 59 inches

4 COMBINATIONS

The vertically opening **DROP GATE** is perfect when space is limited but there's ample height. This gate type modularly integrates with other safety solutions in the FLEX IMPACT® range. Together, these safety elements ensure smooth and safe movement between different areas in your facility.

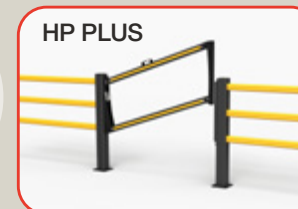

BB BELT BARRIER



QUICKLY CLOSE OFF CRITICAL AREAS

The FLEX IMPACT® **BELT BARRIER** lets you quickly cordon off a doorway, gate, or loading bay. This prevents pedestrians from walking into the path of moving vehicles, stepping into uncovered openings, or entering areas under maintenance.



VISUAL BARRIER

Wherever there is a hazard risk, the **BELT BARRIER** can be easily mounted on poles or walls. When these areas are safe to access, the belt can be left open. If necessary, the belt can be quickly closed to prevent pedestrians from entering the area. Its yellow color ensures excellent visibility, which further increases safety.

KEY FEATURES AND FUNCTIONS

- Visual barrier
- Quick and temporary area closure
- Highly visible with yellow/black stripes
- Durable and built for heavy use
- Automatic retractable mechanism
- For openings up to 0.4 inches
- Easily mounts between walls or to a Boplan polymer post

JOULES

MAKE IMPACT TANGIBLE



The joule is a fundamental unit of physics and offers a perfect way to quantify energy in everyday life. That's why we use this unit to express the impact resistance of our FLEX IMPACT® safety products.

Simply put, joules are the energy units used to measure the amount of work or energy required to do something. It tells you how much energy is used, transferred or converted in a given situation.

BOPLAN IMPACT CALCULATOR

With the Boplan Impact Calculator, you can accurately calculate the required impact resistance for your safety solutions. This powerful tool is easy to use and helps you make informed decisions with just a few clicks.

Enter specific parameters related to your workspace to instantly receive recommendations on the most suitable models and strength levels of safety products to prevent accidents and protect valuable assets.



DOCK GATE



FALL PROTECTION SYSTEM
AND IMPACT-RESISTANT
BARRIER ARM FOR LOADING ZONES

The FLEX IMPACT® DOCK GATE is a safety gate with double bars, providing fall protection at loading docks or serving as an impact-resistant barrier arm to close off access to specific areas.

The safety gate includes an assist mechanism with ergonomic handles on the side and underneath, ensuring smooth and easy operation. Additionally, a motorized version is available.

PROTECTION AGAINST IMPACTS UP TO 16 kJ

THE FIRST AND ONLY SAFETY GATE WORLDWIDE TESTED
FOR BOTH BARS AND POSTS ACCORDING
TO THE UNI TS 11886 STANDARD.

With its tube-in-tube structure and strong base plates, the gate offers protection against impacts up to 16 kJ to both bars and posts.

Its compact design ensures no valuable space is wasted. The DOCK GATE includes removable bars for easy assembly. Installation is also quick, as each DOCK GATE consists of three pre-assembled elements.





Our DOCK GATES are made from Extrilene, a high-quality polymer material. This material is ideal for absorbing heavy impacts.

EXTRILENE®

Crash tests have shown that our DOCK GATES can withstand impacts of up to 16 kJ. To both the bars and posts. The deformation that occurs after each collision disappears once the vehicle has passed.

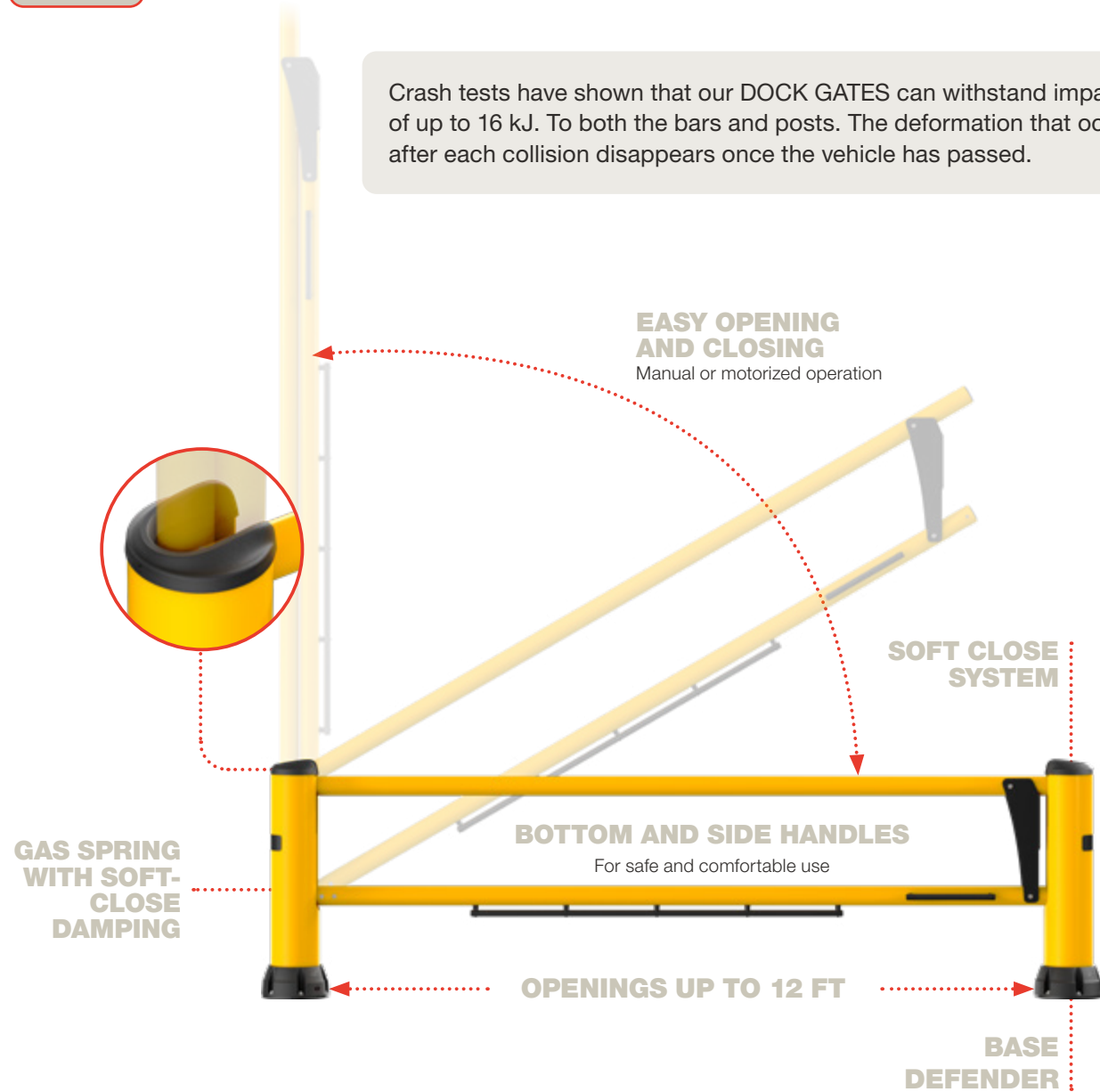

KEY FEATURES AND BENEFITS



EASY INSTALLATION THANKS TO MODULAR DESIGN

Our DOCK GATE is constructed with minimal components. In addition, all parts are neatly concealed within the posts. With its compact design, the gate takes up minimal space. For easy assembly and transport, the DOCK GATE includes removable bars.



RESISTANT TO CHEMICALS AND UV RAYS

Our DOCK GATES resist chemicals and UV rays. They are ideal for environments where chemicals are frequently used or where strict hygiene standards apply. Bacteria do not adhere to the polymer, making it easy to clean.



OPTIMAL VISIBILITY

The standard color for these safety gates is yellow. Yellow attracts attention and increases safety awareness.



LOW MAINTENANCE

A FLEX IMPACT® DOCK GATE requires minimal maintenance. With proper use, our systems have an exceptionally long lifespan.



A REVOLUTIONARY BASE PLATE

An optimized base plate increases impact resistance. The Base Defender protects the screws anchoring the round base plate to the floor. This durable elastomer cover makes it physically impossible to drive over the base plate and damage the screws. The Base Defender is wider than the bollard. This creates a free space and prevents fingers from crushing.

STRONGER THAN EVER

The DOCK GATE includes Extrilene tubes of varying lengths, bolted to the base plate. The different tubes provide optimal impact absorption through deformation and friction.

✓ PATENTED

TYPICAL ENVIRONMENTS

Fall protection system and impact-resistant barrier arm for loading zones in:

- Distribution centers
- Transport & logistics centers
- Warehouses and storage facilities
- Logistics, supply chain and material handling



MANUAL DOCK GATE



DG250R
10.2 kJ TO THE BARS AND POSTS

MOTORIZED DOCK GATE

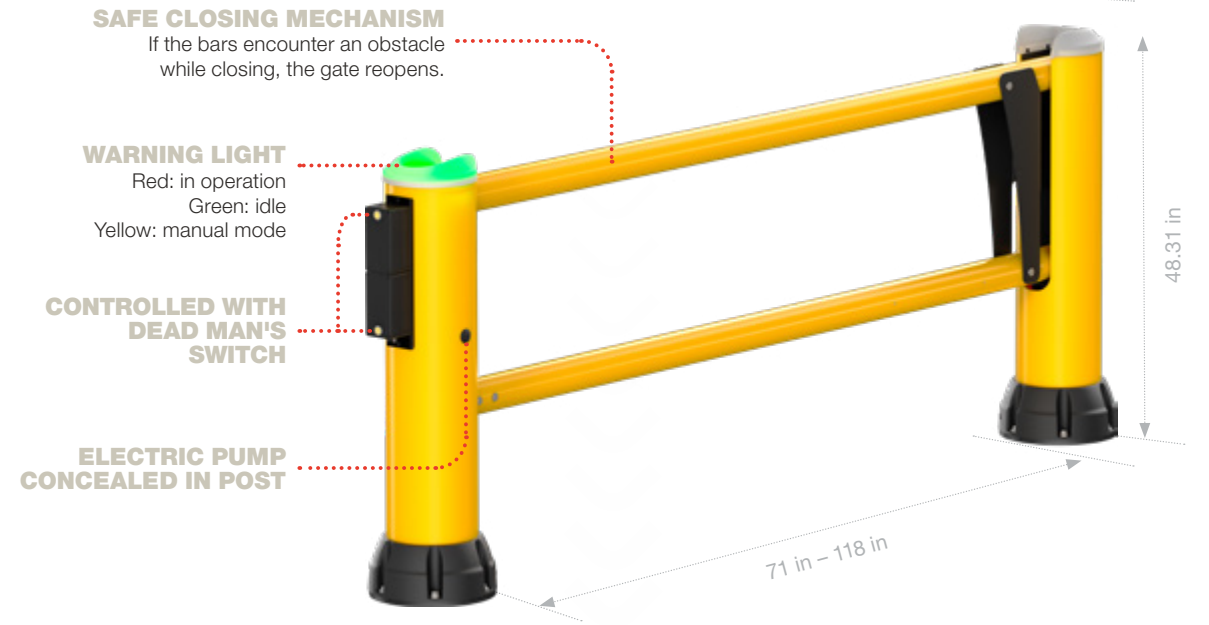

DG250R AE
10.2 kJ TO THE BARS

MANUAL DOCK GATE THE STRONGEST
POLYMER GATE IN THE WORLD

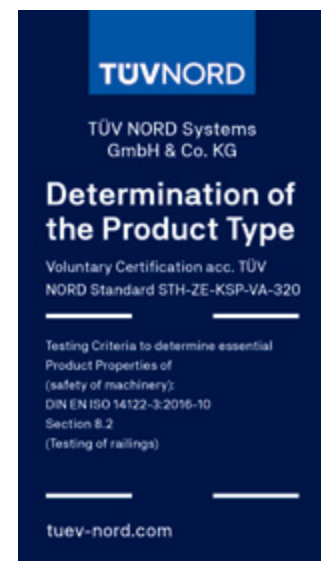

DG250F
16 kJ TO THE BARS AND POSTS

BUILT FOR HIGH-RISK INDUSTRIAL ENVIRONMENTS

Engineered for demanding industrial environments like loading docks, logistics platforms, and production areas, our DG250R AE motorized safety gate provides robust protection for both people and infrastructure. By reducing fall hazards and mitigating the risk of vehicle impacts, this safety gate ensures a secure working environment.

STRONG BARRIER PERFORMANCE

When closed, the DG250R AE functions as a strong, impact-resistant polymer gate, delivering up to 10.2 kJ of tested energy absorption on both rails. When opened, its patented internal motorized system allows safe, controlled, and ergonomic access.

SAFE, CONTROLLED, AND SMART OPERATION

A two-hand control system activates the gate's movement, while integrated safety sensors immediately

stop the gate if resistance is detected. A flashing red light and acoustic signal warn when the gate is moving, switching to a steady green light once the gate reaches its end position. For exceptional circumstances, a manual release mechanism can be used in combination with the yellow indicator confirming manual mode.

COMPACT DESIGN

The DG250R AE integrates its motorization inside the hinge post, decreasing the number of exposed components and simplifying installation. Base Defenders protect ground anchors and enhance ground-level safety, while a digital cycle counter helps with inspections and preventive maintenance planning.

FIVE MODELS

Available in five models with opening widths of 71" to 118", our DG250R AE is a versatile, durable, and high-performance solution for facilities in need of a dependable safety gate in a bright, highly visible yellow.

BOPLAN HEADQUARTERS

Muizelstraat 12
8560 Moorsele, Belgium
+32 56 20 64 20
info@boplan.com

BOPLAN USA

4350 W. White Road, St 300
Flowery Branch, GA 30542
+1 678-890-5906
info@boplan.us

BOPLAN UK

Science Centre, Wolverhampton Science Park
Glaisher Drive, Wolverhampton WV10 9RU
+44 1902 82 4280
info@boplan.co.uk

BOPLAN DEUTSCHLAND

IHP-Nord · Babenhäuser Str. 50
63762 Großostheim
+49 6026 999 51 90
info@boplan.de

BOPLAN FRANCE

617, Avenue de Bayonne
64210 Bidart
+33 (0)5 35 45 75 35
info@boplan.fr

BOPLAN ESPAÑA

Carrer d'Aragó 208, 2o 6a
08002 Barcelona
+34 936 81 66 88
info@boplan.es

BOPLAN NEDERLAND

Toermalijnring 100
3316 LC Dordrecht
+31 85 13 07 500
info@boplan.nl

BOPLAN POLSKA

Ul. Graniczna 34B / U16
41-300 Dąbrowa Górnicza
+48 32 224 74 85
info@boplan.pl

BOPLAN ITALIA

Via Privata Maria Teresa 7
20123 Milano
+39 02 81287168
info@boplan.it

BOPLAN JAPAN

4F Matsuoka II Building,
1-2-11 Nijyooji Minami
Nara City, Nara 630-8012
+81 (0)742-93-8705
info@boplan.co.jp

FOLLOW US



BOPLAN.COM

For more information about our products,
services, and worldwide network

