

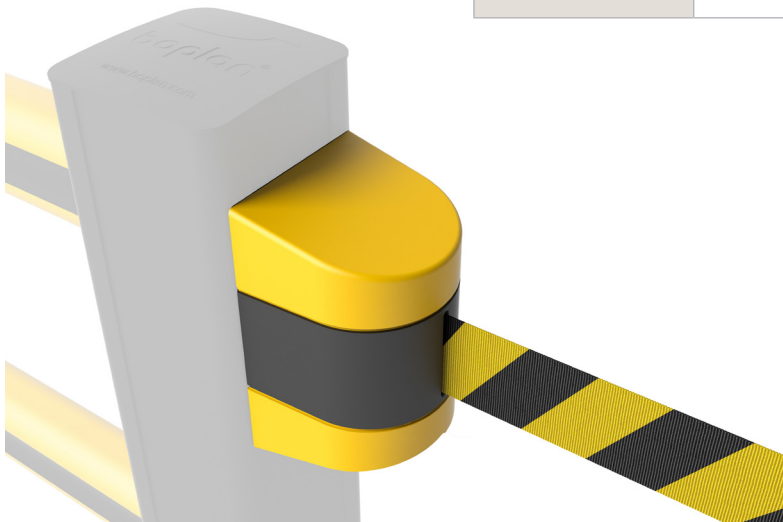

BB BELT BARRIER

SAFETY GATES

Revision: 8 July 2025 12:02 PM
Boplan reference: BB-...

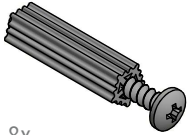
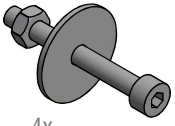

PRODUCT SPECIFICATIONS

APPLICATION		
Environment	Quickly open and close restricted areas with the help of a belt barrier. Indoor use only.	
Features	Automatic retracting mechanism Available in two lengths Highly visible because of the yellow / black strips on the webbing Easy to mount between walls, on a Boplan plastic post or between metal racks All fixations are included, also magnets for mounting on a metal structure	
Operational temperature	-20°C up to +40°C	
Attach to	A wall, rack beam, or other structure. 5 meter version: possible to attach to HP plus post (NOT to a HD Light post). 10 meter version: not possible to attach to HP plus or HD light post.	
MATERIAL		
Housing	ABS	
Webbing	Nylon	
Internal components	Steel and plastic (spring in stainless steel)	
STANDARD COLOURS		
Housing	Black body with yellow caps	
Belt	Hazard (HZ) = Yellow / black stripes	
SIZE AND PROPERTIES		
	Belt Barrier - 5m (± 0,2)	Belt Barrier - 10m (± 0,2)
Outer dimensions	145(H) x 95 (W) x 90 (D)	167 (H) x 117 (W) x 109 (D)
Weight	490 gram	990 gram
FIXATIONS (included)		
Type	<div style="display: flex; justify-content: space-around; align-items: flex-start;"> <div style="text-align: center;">  8x Cross head screw ZC: 30mm x Ø4mm Plug: 30mm x Ø9mm </div> <div style="text-align: center;">  4x Nut M4 - ZC Bolt M4x25mm - ZC Washer - ZC </div> <div style="text-align: center;">  1x Holder 40mm x 80mm </div> </div>	

REFERENCES - BB BELT BARRIER

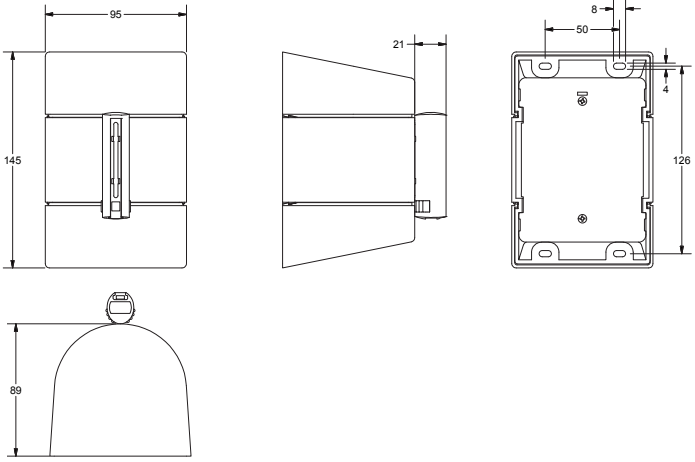
<p>BB0050-0050-HZ</p>	<p>Belt Barrier - 5M Colour Belt: Hazard</p>	
<p>BB0100-0050-HZ</p>	<p>Belt Barrier - 10M Colour Belt: Hazard</p>	