

TB 260 DOUBLE PLUS

SAFETY BARRIERS

Revision: 29 January 2026 9:04 AM
Boplan reference: DP260...



PRODUCT SPECIFICATIONS

APPLICATION			
Environment	Just like the TB400 Double Plus, the TB260 Double Plus offers protection against impacts from heavier vehicles. Its lower tube is specifically designed to prevent goods or pallets from sliding under the barriers, reducing the potential harm to pedestrians or machinery.		
Impact performance at 90°	POST: 39800 Joule (Eq. to 10 ton - 6.3 mph)		
	RAIL: 46500 Joule (Eq. to 10 ton - 6.8 mph)		
MATERIAL			
Posts and rails	Extrilene - UV resistant - Fire class E [*] - Non conductive - Impervious to most chemicals ^{**}		
Caps	Sustainable elastomer		
STANDARD COLORS			
End post	Yellow RAL 1003		
Mid post	Yellow RAL 1003		
Tubes (rails)	Yellow RAL 1003		
BASEPLATES			
	Steel	Zinc Coated Steel	Stainless steel
Material	Steel 37	Steel 37	Stainless steel 304
Coating	Lacquered	Lacquered + electro plating	No Itacquer / No coating
Color	High gloss black	Matt black	Natural color

*Classification according to EN 13501-1:2007 +A1:2009 - Fire classification of construction products and building elements.

**Ask your local sales office for resistance to specific chemicals.

FIXATIONS				
			ZC (Zinc coated)	SS (Stainless steel)
STANDARD	Wedge anchor		3/4 in x 5 1/2 in	not available
	Wedge anchor		Ø18mm (M12) x 130mm	Ø18mm (M12) x 130mm
ALTERNATIVES	Anchor rod (Chemical)		M16 x 120mm + Chemical resin	M16 x 120mm + Chemical resin
	Concrete screw		Ø17mm x 130mm	Not available

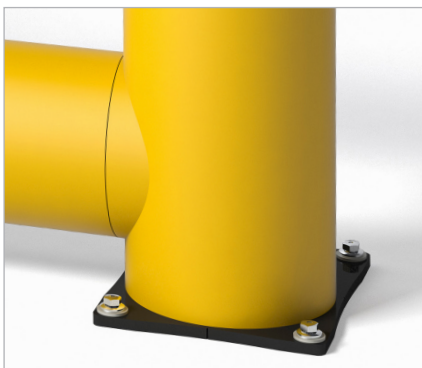

FEATURES AND FUNCTIONALITY - TB 260 DOUBLE PLUS

SIZE	
Height end posts	45 1/3 in
Height mid post	45 1/3 in
Profile section tubes	Ø8 in (2/5 in thick)
Profile section handrails	2 x 2 3/4 in (1/5 in thick)
Profile section end posts	Outer tube: Ø10 in (2/5 in thick) Inner profile: 4 2/5 x 4 2/5 in (1/3 in thick)
Profile section mid posts	Profile: 4 2/5 x 4 2/5 in (1/3 in thick)
Standard rail length	CC60 in (Tube length - 50 in)
Baseplate	End Post: 12 2/3 x 10 4/5 in (1/2 in thick) Mid Post: 12 2/3 x 10 4/5 in (1/2 in thick)

REQUIREMENTS	
Concrete quality	minimum 4000 PSI (C25/30)
Concrete floor plate thickness	minimum 6 in
Concrete slab dimension around posts (in)	31 1/2 (H) x 31 1/2 (W) x 23 2/3 (D)
Operational temperature	14 °F up to 104 °F
Water and humidity	Steel (standard): dry indoor use only. Zinc coated: outdoor use in most environments. Stainless Steel: outdoor use or frequent exposure to water and humidity.

IMPACT LABEL FOR SAFETY BARRIERS

BOPLAN TB 260 DOUBLE PLUS		
IMPACT RATING	45°	90°
E80 < 80 kJ	65,7 kJ	
E60 < 60 kJ		
E50 < 50 kJ		
E40 < 40 kJ		46,5 kJ
E35 < 35 kJ		
E30 < 30 kJ		
E25 < 25 kJ		
E20 < 20 kJ		
E15 < 15 kJ		
E10 < 10 kJ		
E5 < 5,0 kJ		
E2 < 2,5 kJ		

TEST CONDITIONS

TEMPERATURE: 20°C / 68°F

IMPACT HEIGHT: 650 mm / 25 2/3 inch

IMPACT ANGLE: 90°

TEST FLOOR: CONCRETE SLAB C25/30 - 160 mm / 6 inch

MANUFACTURER ANCHOR PULL OUT: 17kN

TEST VEHICLE

WEIGHT: 2300 KG / 5070.63 lbs

TYPE: COMMERCIAL FORK LIFT

SIZE (L x W x h): 1890x1020x1970 mm / 74x40x78 Inch

CONTACT AREA: STEEL BUMPER WIDTH: 600 mm / 24 Inch

ACCREDITED TEST LABORATORY

620 Route des Fromentaux

01500 Saint-Maurice-de-Rémens

01360 Bèlignieux



France

SUCCESS CRITERIA VEHICLE STOPPED - ASI (ACCELERATION SEVERITY INDEX) <0.5

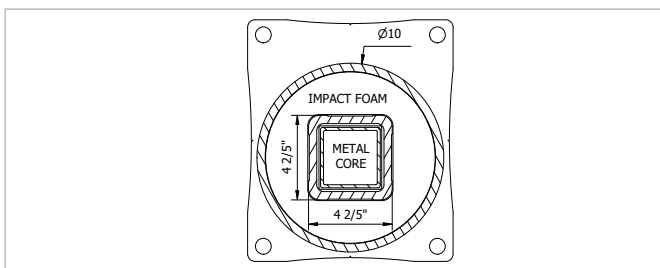
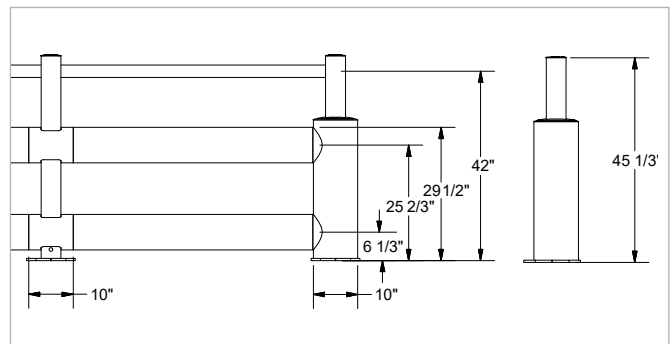
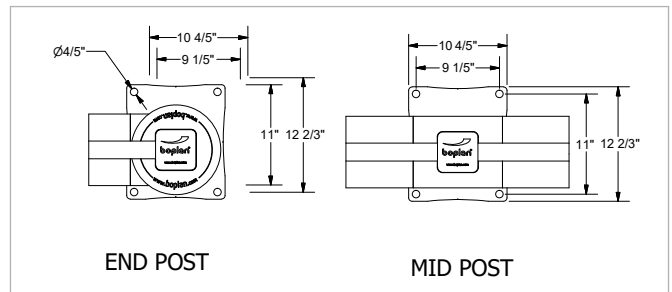
IL-DP260-20230707

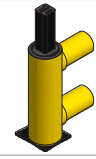
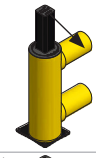
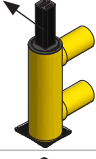
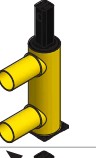
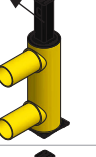
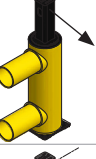
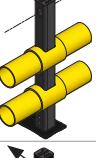

REFERENCE LIST - TB260 DOUBLE PLUS

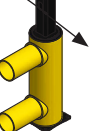
POSTS		
End post Left End post Left - ZC End post Left - SS	DP2600-0001-EPLYE DP2600-0001-EPLYEZ DP2600-0001-EPLYES	
Corner post Left - 90° - Up Corner post Left - 90° - Up - ZC Corner post Left - 90° - Up - SS	DP2600-0001-CPULYE DP2600-0001-CPULYEZ DP2600-0001-CPULYES	
Corner post Left - 90° - Down Corner post Left - 90° - Down - ZC Corner post Left - 90° - Down - SS	DP2600-0001-CPDLYE DP2600-0001-CPDLYEZ DP2600-0001-CPDLYES	
End post Right End post Right - ZC End post Right - SS	DP2600-0001-EPRYE DP2600-0001-EPRYEZ DP2600-0001-EPRYES	
Corner post Right - 90° - Up Corner post Right - 90° - Up - ZC Corner post Right - 90° - Up - SS	DP2600-0001-CPURYE DP2600-0001-CPURYEZ DP2600-0001-CPURYES	
Corner post Right - 90° - Down Corner post Right - 90° - Down - ZC Corner post Right - 90° - Down - SS	DP2600-0001-CPDRYE DP2600-0001-CPDRYEZ DP2600-0001-CPDRYES	
Mid post Mid post - ZC Mid post - SS	DP2600-0001-MPYE DP2600-0001-MPYEZ DP2600-0001-MPYES	
T end post Left* T end post Left - ZC* T end post Left - SS*	DP2600-0001-TPLYE DP2600-0001-TPLYEZ DP2600-0001-TPLYES	
T end post Right* T end post Right - ZC* T end post Right - SS*	DP2600-0001-TPRYE DP2600-0001-TPRYEZ DP2600-0001-TPRYES	

* 2 Caps included to close handrail hole

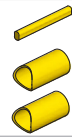
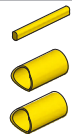
CURVES			
Conn.tube Ø10 Curve 14in - YE	DP2600-0350-C250YE		
Conn.tube Ø10 - 90° Curve 14in - YE	DP2600-0350-C259YE		
RAIL SETS			
	Tube length (A)	CC length (B)	Reference
Standard rail	26 in	36 in	DP2600-0665-0915YE
Standard rail	38 in	48 in	DP2600-0970-1220YE
Standard rail	50 in	60 in	DP2600-1275-1525YE
Standard rail	62 in	72 in*	DP2600-1578-1828YE
Standard rail	68 in	78 in*	DP2600-1730-1980YE
Short rail	36 - 48 in	46 - 58 in	DP2609-0048-SRYE
Long rail	48 - 60 in	58 - 70 in*	DP2609-0060-LRYE
Long rail	60 - 72 in	70 - 82 in*	DP2609-0072-LRYE
Long rail	72 - 78 in	82 - 88 in*	DP2609-0078-LRYE

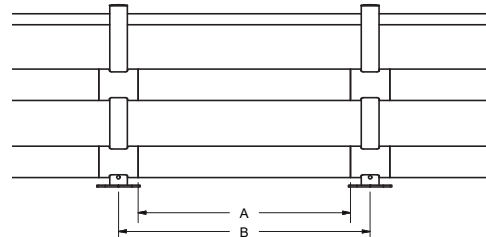

* The impact performance has not been tested for tube lengths > 63 in. Only use these lengths for non - critical applications.

REFERENCE LIST - TB260 DOUBLE PLUS
FIXED UNITS

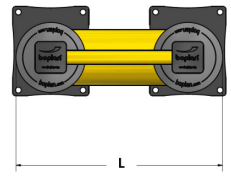
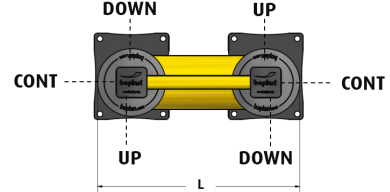
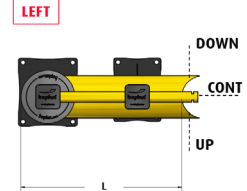
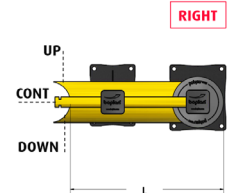
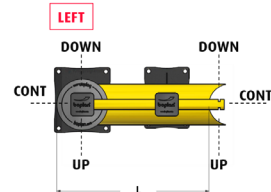
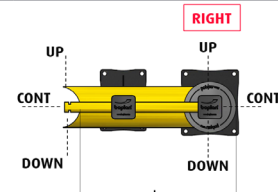
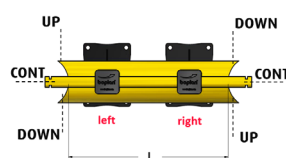
TYPE	LENGTH	BASE	YELLOW		
no curves	Endpost	30 in	Steel ZC SS	DP2600-0750-FUYE DP2600-0750-FUYEZ DP2600-0750-FUYES	
		30 - 68 in	Steel ZC SS	DP2601-1750-FUYE DP2601-1750-FUYEZ DP2601-1750-FUYES	
	Post <i>Up</i> <i>Down</i> <i>Continu</i>	30 in	Steel ZC SS	DP2602-0750-FUYE DP2602-0750-FUYEZ DP2602-0750-FUYES	
		30 - 68 in	Steel ZC SS	DP2602-1750-FUYE DP2602-1750-FUYEZ DP2602-1750-FUYES	
1 curve	Endpost LEFT	30 in	Steel ZC SS	DP2600-0750-FU1CLYE DP2600-0750-FU1CLYEZ DP2600-0750-FU1CLYES	
		30 - 68 in	Steel ZC SS	DP2601-1750-FU1CLYE DP2601-1750-FU1CLYEZ DP2601-1750-FU1CLYES	
	Endpost RIGHT	30 in	Steel ZC SS	DP2600-0750-FU1CRYE DP2600-0750-FU1CRYEZ DP2600-0750-FU1CRYES	
		30 - 68 in	Steel ZC SS	DP2601-1750-FU1CRYE DP2601-1750-FU1CRYEZ DP2601-1750-FU1CRYES	
	Post LEFT <i>Up</i> <i>Down</i> <i>Continu</i>	30 in	Steel ZC SS	DP2602-0750-FU1CLYE DP2602-0750-FU1CLYEZ DP2602-0750-FU1CLYES	
		30 - 68 in	Steel ZC SS	DP2602-1750-FU1CLYE DP2602-1750-FU1CLYEZ DP2602-1750-FU1CLYES	
	Post RIGHT <i>Up</i> <i>Down</i> <i>Continu</i>	30 in	Steel ZC SS	DP2602-0750-FU1CRYE DP2602-0750-FU1CRYEZ DP2602-0750-FU1CRYES	
		30 - 68 in	Steel ZC SS	DP2602-1750-FU1CRYE DP2602-1750-FU1CRYEZ DP2602-1750-FU1CRYES	
2 curves	32 in	Steel ZC SS	DP2600-0800-FU2CYE DP2600-0800-FU2CYEZ DP2600-0800-FU2CYES		
	32-38 in	Steel ZC SS	DP2601-1750-FU2CYE DP2601-1750-FU2CYEZ DP2601-1750-FU2CYES		