

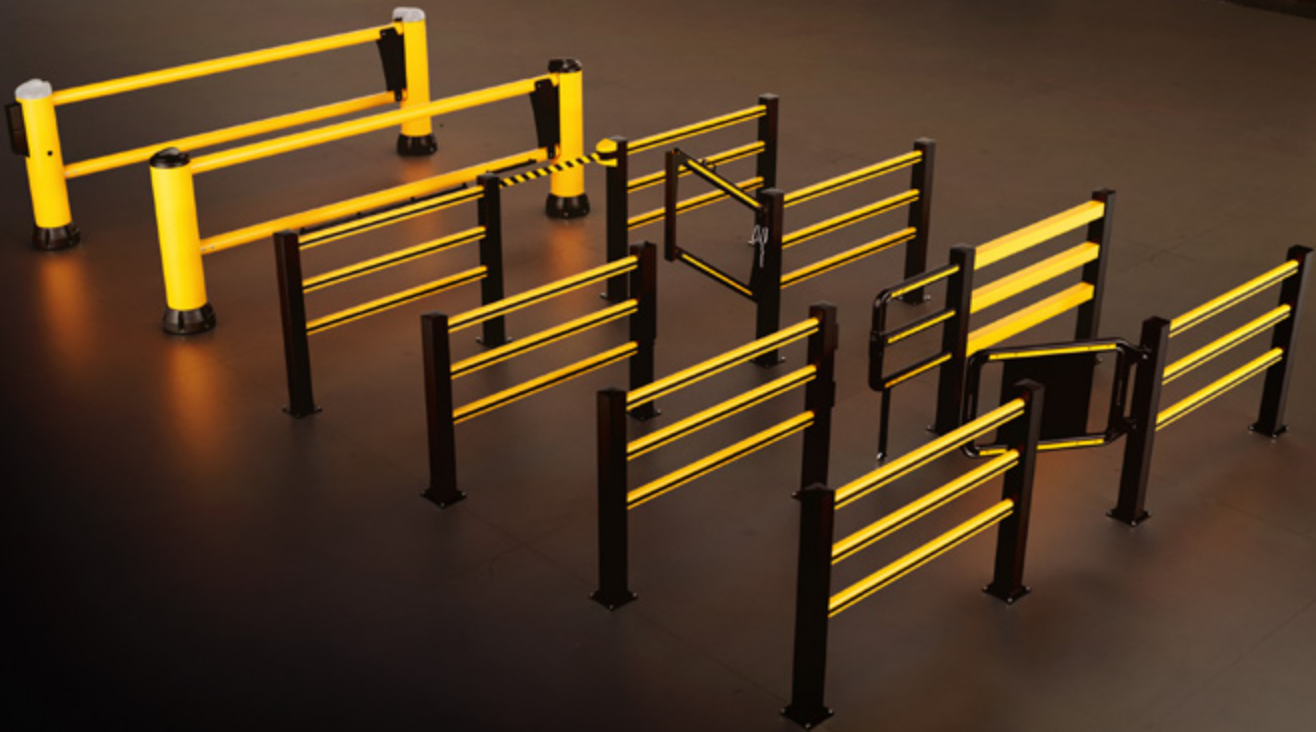

**READY
FOR
IMPACT**



SAFETY GATES

**RESTRICTING ACCESS
TO HAZARDOUS AREAS**



SG SWING GATE



SWING GATE

The FLEX IMPACT® **SG SWING GATE** is a two-way safety gate. Gates and entrances to corridors and machine rooms are often left open. The SG SWING GATE makes this a thing of the past. This safety gate closes automatically so that access remains restricted at all times. The sturdy door is ergonomically designed and features a sign.

LARGE SIGN BOARD

Warns employees and visitors of hazards

GATE STOP

Prevents the gate from swinging in a specific direction

LOCK BLOCK

Prevents the gate from locking in an open position

WHEEL SUPPORT

Standard for gates wider than 1,500 mm



Combination of a **SWING GATE** with a **TB 400 PLUS** at the **Instantprint (United Kingdom)** warehouse.

Read the full case online

KEY FEATURES AND FUNCTIONS

- Robust, impact-resistant safety gate that swings open
- Close off aisles in areas with incoming and outgoing goods
- Clear demarcation of beginning and end of pedestrian areas: warning function
- Saline and corrosive environments (food industry, coastal areas, etc.)
- Close off access routes to machine rooms
- Suitable for outdoor use (optional SS 304 stainless steel components)
- Durable and capable of withstanding heavy use
- Ergonomic design
- Can be combined with safety barriers, handrails and bollards
- Large sign board
- Lock block and stop
- Wheel support for gates wider than 1,500 mm



4 POSSIBLE COMBINATIONS

The **SG SWING GATE** combines perfectly with FLEX IMPACT® safety barriers and handrails. Together, these safety elements ensure smooth and safe traffic between the different areas in your working environment.

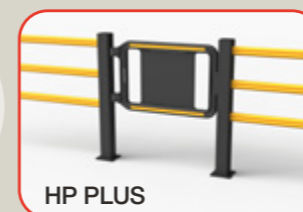

SG SLIDING GATE



SAFETY GATE THAT OPENS AND CLOSSES BY SLIDING

The FLEX IMPACT® **SG SLIDING GATE** is a safety gate that opens and closes by sliding. You can have the gate slide to the left or right. When the gate opens, it rolls across the floor on a sturdy wheel and its rails slide into the profiles of the adjoining guardrail. This safety gate is easy to install.

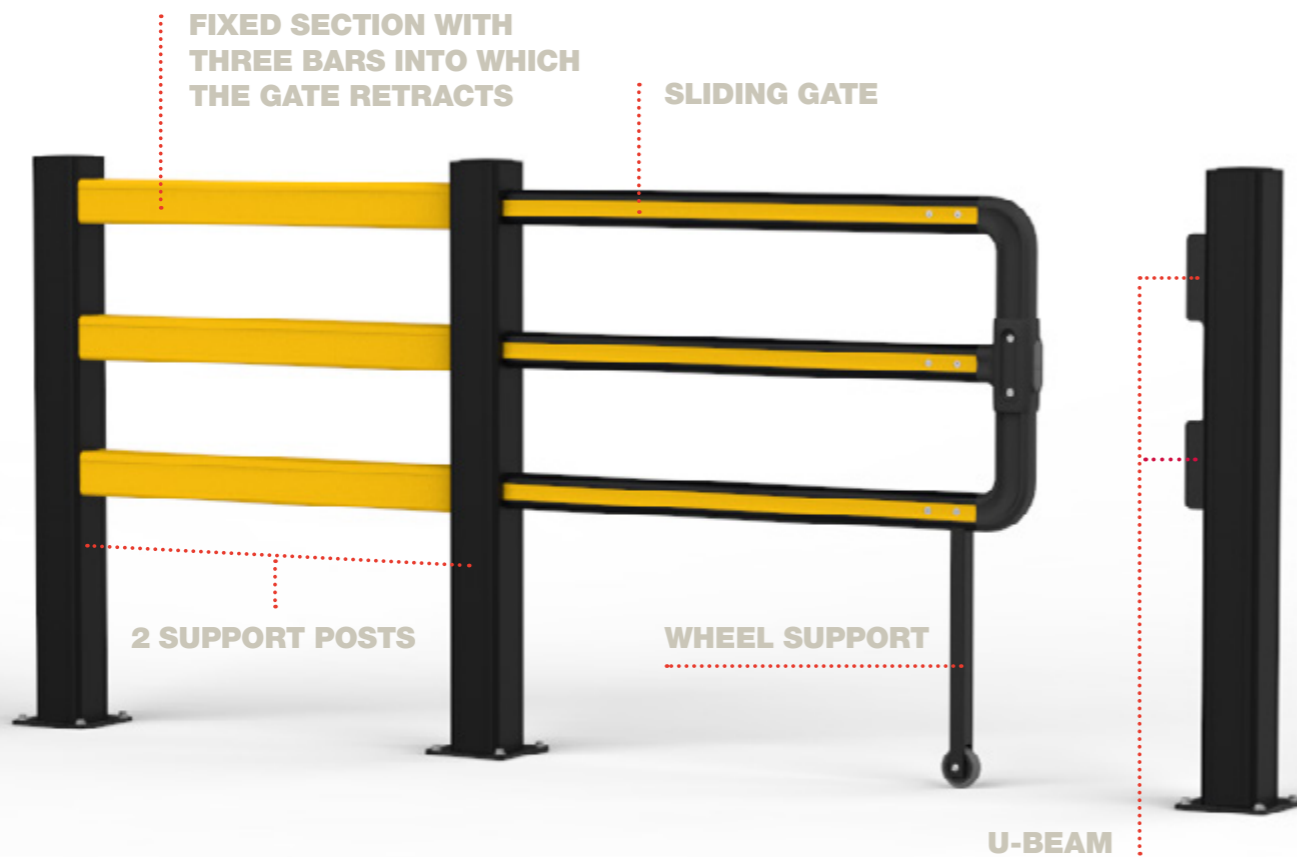

KEY FEATURES AND FUNCTIONS

- Sliding safety gate
- Close off access routes to machine rooms
- Close off aisles in areas with incoming and outgoing goods
- Durable and capable of withstanding heavy use
- Clear demarcation of beginning and end of pedestrian areas
- Ergonomic design
- Saline and corrosive environments (food industry, coastal areas, etc.)
- Can be combined with safety barriers and handrails

COMBINABLE WITH SAFETY BARRIERS AND HANDRAILS

The SLIDING GATE is part of the impact-resistant and attractive FLEX IMPACT® series. A sliding safety gate is ideal for spaces with limited room for movement. Additionally, the SLIDING GATE combines perfectly with our safety barriers and handrails. Together, these safety products ensure that people can circulate safely.



SG DROP GATE



SAFETY DROP GATE THAT OPENS UPWARD

The FLEX IMPACT® **SG DROP GATE** is a safety gate that closes off access routes when there isn't enough space to use a traditional swing gate. This gate opens upward. Just like the other safety gates in this series, the SG DROP GATE is a convenient solution to cordon off walkways and areas.

CONVENIENT HANDLE

SUPPORT

STURDY HINGE

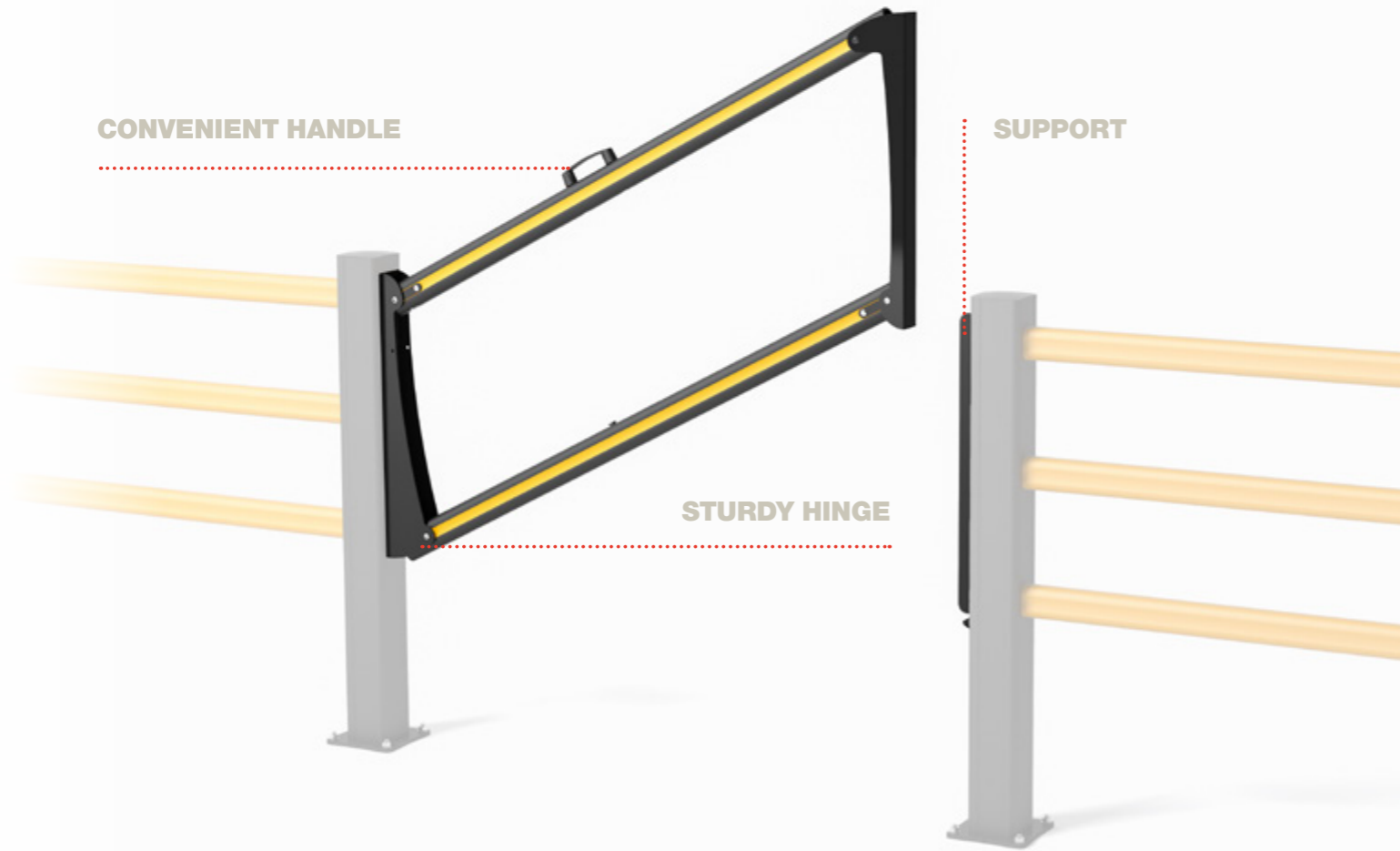

KEY FEATURES AND FUNCTIONS

- Safety drop gate that opens upward
- Close off aisles without enough room for a swing gate
- Saline and corrosive environments (food industry, coastal areas, etc.)
- Close off access routes to machine rooms
- Durable and capable of withstanding heavy use
- Ergonomic design
- Can be combined with safety barriers and handrails
- For openings up to 1,500 mm

4 COMBINATIONS

The vertically opening **DROP GATE** is ideal when space is limited but there's plenty of height. This type of gate integrates modularly with other safety solutions from the FLEX IMPACT® range. Together, these safety elements ensure smooth and safe traffic between different areas at your company.

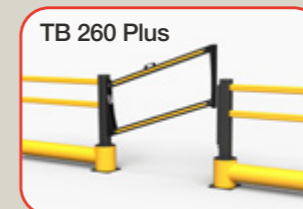
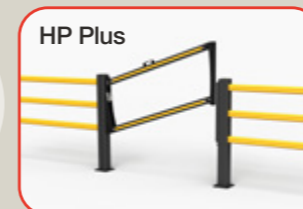

BB BELT BARRIER



QUICK CLOSURE OF CRITICAL AREAS

With the FLEX IMPACT® **BELT BARRIER**, you can quickly cordon off a doorway, gate or loading bay. This prevents pedestrians from walking into the path of moving vehicles, stepping into uncovered openings or entering an area where maintenance works are being carried out.



A VISUAL BARRIER

Wherever there is a risk of danger, the **BELT BARRIER** can be easily attached to posts or walls. When these areas are safely accessible, leave the belt open to allow access. If necessary, close the belt quickly to prevent pedestrians from entering the area. Its yellow colour ensures excellent visibility, further increasing safety.

KEY FEATURES AND FUNCTIONS

- Visual barrier
- Quick and temporary closure of areas
- Highly visible thanks to the yellow/black stripes
- Durable and capable of withstanding heavy use
- Automatic retractable mechanism
- For openings up to 10 metres
- Easily mounted between walls or to a Boplan polymer post

JOULES

MAKE IMPACT TANGIBLE



The joule is a fundamental unit of physics and offers a perfect way to quantify energy in everyday life. That's why we use this unit to express the impact resistance of our FLEX IMPACT® safety products.

Simply put, joules are the energy units used to measure the amount of work or energy required to do something. It tells you how much energy is used, transferred or converted in a given situation.

BOPLAN IMPACT CALCULATOR

With the Boplan Impact Calculator, you can accurately calculate the required impact resistance for your safety solutions. This powerful tool is easy to use and allows you to make informed decisions with just a few clicks.

Enter specific parameters related to your workspace to instantly receive recommendations on the most suitable models and strength levels of safety barriers to avoid accidents and protect valuable assets.



DOCK GATE



FALL PROTECTION SYSTEM AND IMPACT-RESISTANT BARRIER ARM FOR LOADING AREAS

The FLEX IMPACT® **DOCK GATE** is a safety gate with double bars that acts as fall protection at loading docks or as an impact-resistant barrier arm to close off access to a specific area.

The safety gate features an assist mechanism and ergonomic handles to the side and underneath for smooth and easy operation. Additionally, a motorised version is also available.

PROTECTION AGAINST IMPACTS UP TO >>>> 16 kJ

THE FIRST AND ONLY ONE IN THE WORLD TO BE TESTED FOR BOTH THE BARS AND POSTS ACCORDING TO THE UNI TS 11886 STANDARD.

Thanks to the tube-in-tube structure and strong base plates, the gate provides protection against impacts up to 16 kJ, both to the bars and to the posts.

The design is very compact, ensuring no valuable space is lost. For easy assembly, the DOCK GATE features removable bars. Installation is also quick, as a DOCK GATE consists of three pre-assembled elements.





Our DOCK GATES are made of EXTRILENE®, a high-quality polymer material. This material is ideal for absorbing heavy impacts.

EXTRILENE®

Crash tests have demonstrated that our DOCK GATES can withstand impacts of 16 kJ. Both to the bars and to the posts. The deformation that occurs after each collision disappears once the vehicle has gone.

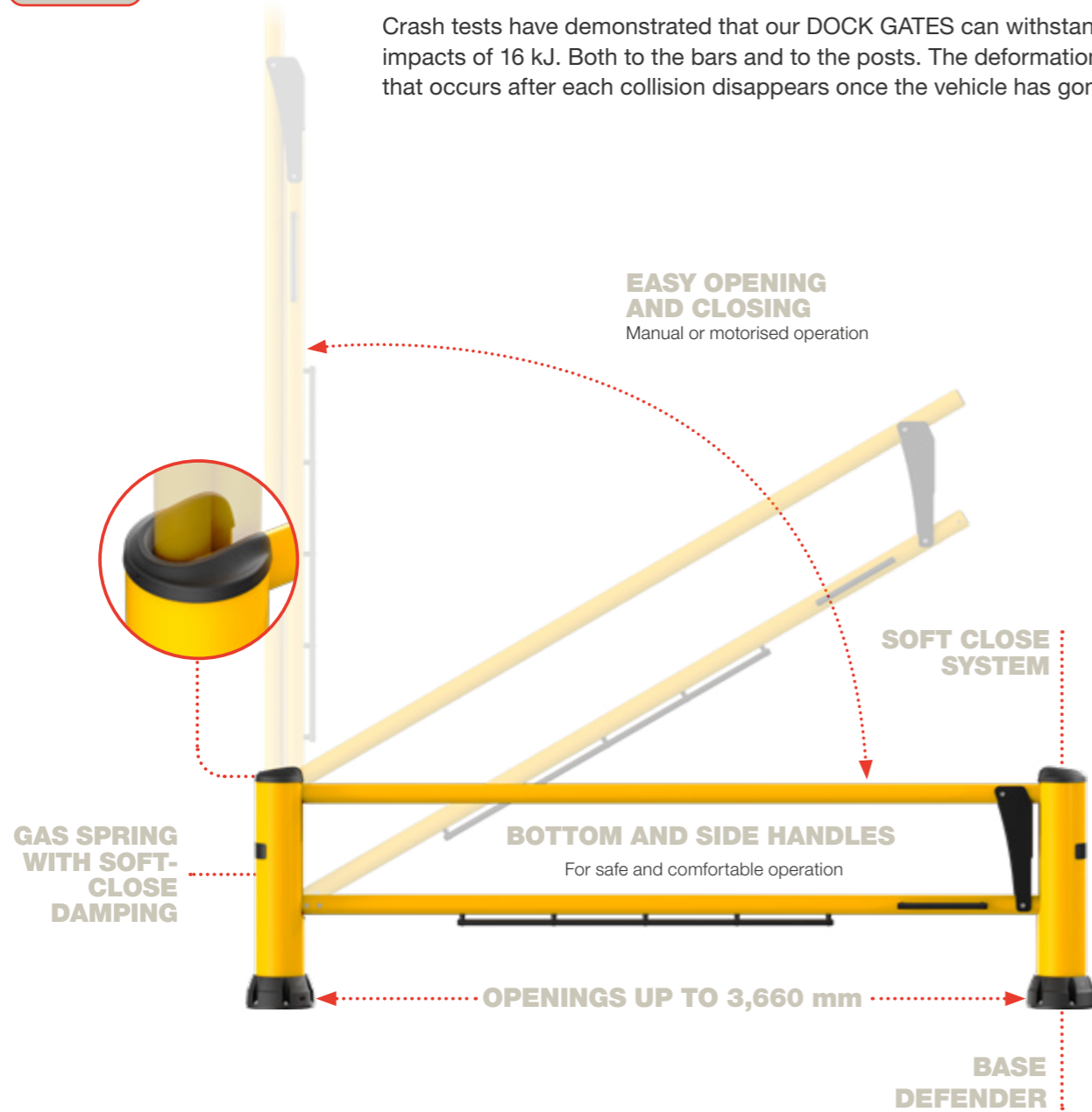

KEY FEATURES AND BENEFITS



EASY INSTALLATION DUE TO MODULAR DESIGN

Our DOCK GATE is constructed using a minimum of components. Moreover, all parts are neatly concealed within the posts. Thanks to its highly compact design, the gate takes up very little space. For easy assembly and transport, the DOCK GATE features removable bars.



RESISTANT TO CHEMICALS AND UV RADIATION

Our DOCK GATES are resistant to chemicals and UV radiation. They are perfect for environments where chemicals are frequently used or where strict hygiene standards apply. Bacteria do not adhere to the polymer and it is easy to clean.



OPTIMAL VISIBILITY

The standard colour for these safety gates is yellow. Yellow draws attention and increases safety awareness.



LOW MAINTENANCE

A FLEX IMPACT® DOCK GATE requires little maintenance. With proper use, our systems last a very long time.



A REVOLUTIONARY BASE PLATE

An optimised base plate increases impact resistance. The Base Defender protects the screws that anchor the round base plate to the floor. This protective cover, made of durable elastomer, makes it physically impossible to drive over the base plate and damage the screws. The Base Defender is wider than the bollard. This creates a free space and prevents crushed fingers.



STRONGER THAN EVER

The DOCK GATE features Extrilene® tubes of various lengths, bolted to the base plate. The different tubes provide optimal impact absorption through deformation and friction.



TYPICAL ENVIRONMENTS

Fall protection system and impact-resistant barrier arm for loading and unloading areas in:

- Distribution centres
- Warehouses and storage facilities
- Transport & logistics centres
- Logistics, supply chain and material handling



MANUALLY OPERATED DOCK GATE



DG250R
10.2 kJ TO THE BARS AND POSTS

MOTORISED DOCK GATE

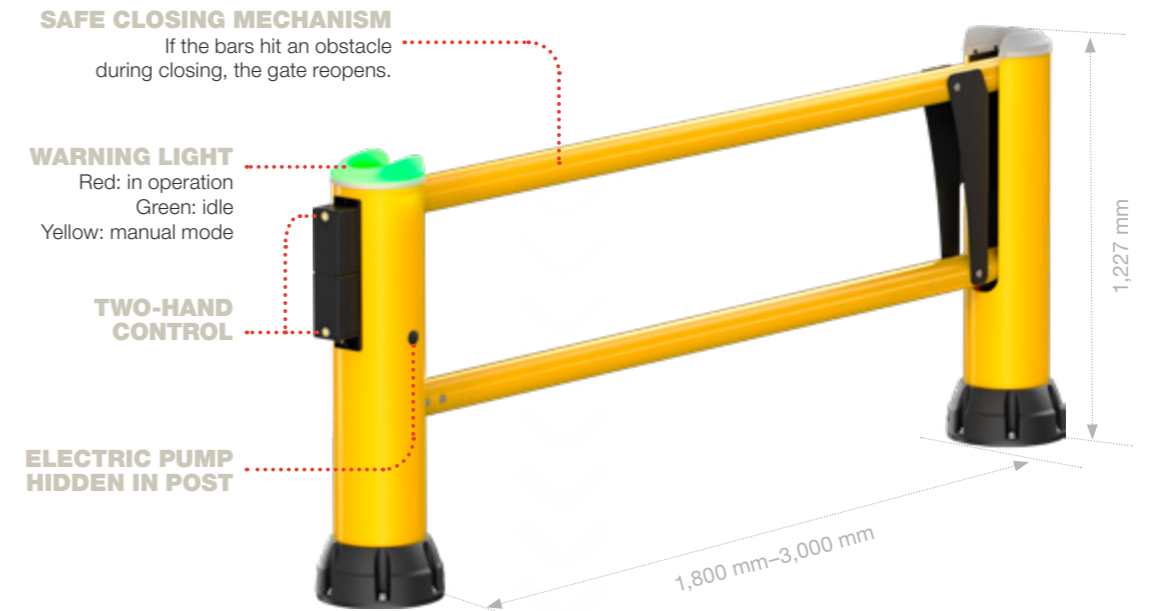

DG250R AE
10.2 kJ TO THE BARS

MANUAL DOCK GATE THE STRONGEST POLYMER GATE IN THE WORLD

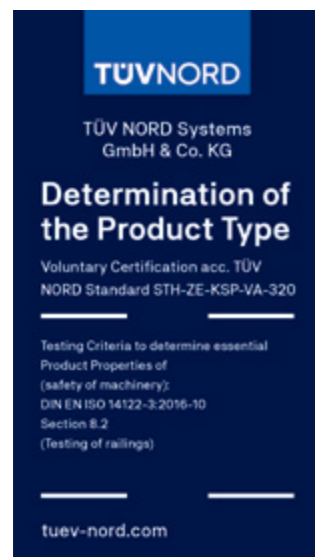

DG250F
16 kJ TO THE BARS AND POSTS

BUILT FOR HIGH-RISK INDUSTRIAL ENVIRONMENTS

Engineered for demanding industrial environments such as loading docks, logistics platforms and production areas, the DG250R AE motorised safety gate provides robust protection for both people and infrastructure. By reducing fall hazards and mitigating vehicle impact risks, it ensures a secure working environment.

STRONG BARRIER PERFORMANCE

When closed, the DG250R AE functions as a strong, impact-resistant polymer gate, delivering up to 10.2 kJ of tested energy absorption on both rails. When opened, its patented internal motorised system enables safe, controlled and ergonomic access.

SAFE, CONTROLLED AND SMART OPERATION

A two-hand control system activates gate movement, while integrated safety sensors immediately stop the gate

if resistance is detected. A flashing red light and acoustic signal warn during movement, switching to a steady green light once the gate reaches its end position. For exceptional circumstances, a manual release mechanism is available, supported by a yellow indicator that confirms manual mode.

COMPACT DESIGN

The DG250R AE integrates its motorisation inside the hinge post, reducing exposed components and simplifying installation. Base Defenders protect ground fixings and enhance ground-level safety, while a digital cycle counter supports inspections and preventive maintenance planning.

FIVE MODELS

Available in five models with opening widths from 1800 to 3000 mm, the DG250R AE offers a versatile, durable and high-performance solution for facilities requiring a dependable safety gate in a bright, highly visible yellow.



**READY
FOR
IMPACT**

BOPLAN HQ

Muizelstraat 12
8560 Moorsele, Belgium
+32 56 20 64 20
info@boplan.com

BOPLAN UK

Science Centre, Wolverhampton Science Park
Glaisher Drive, Wolverhampton WV10 9RU
+44 1902 82 4280
info@boplan.co.uk

BOPLAN USA

4350 W. White Road, St 300
Flowery Branch, GA 30542
+1 678-890-5906
info@boplan.us

BOPLAN DEUTSCHLAND

IHP-Nord · Babenhäuser Str. 50
63762 Großostheim
+49 6026 999 51 90
info@boplan.de

BOPLAN FRANCE

617, Avenue de Bayonne
64210 Bidart
+33 (0)5 35 45 75 35
info@boplan.fr

BOPLAN ESPAÑA

Pl Ramon Berenguer el Gran, 1
08002 Barcelona
+34 936 81 66 88
info@boplan.es

BOPLAN NEDERLAND

Toermalijnring 100
3316 LC Dordrecht
+31 85 13 07 500
info@boplan.nl

BOPLAN POLSKA

Ul. Graniczna 34B / U16
41-300 Dąbrowa Górnicza
+48 32 224 74 85
info@boplan.pl

BOPLAN ITALIA

Via Privata Maria Teresa 7
20123 Milano
+39 02 81287168
info@boplan.it

BOPLAN JAPAN

4F Matsuoka II Building,
1-2-11 Nijyooji Minami
Nara City, Nara 630-8012
+81 (0)742-93-8705
info@boplan.co.jp

FOLLOW US



BOPLAN.COM

For more information about our products,
services and worldwide network

